



DRASH[®]
THE WARFIGHTER'S CHOICE

Reeves[®]
EMS



RUGGED. RELIABLE. VERSATILE.
SHELTER SOLUTIONS FOR MULTI-MISSION CHALLENGES

ABOUT DHS SYSTEMS

Since its inception more than 25 years ago, DHS Systems LLC has evolved to become recognized around the world as the leader in soft-walled shelter technology and support equipment.

DHS Systems has the capabilities to provide solutions for the armed forces, healthcare providers, government at all jurisdictional levels, civilian relief organizations and private enterprise. Our core mission is focusing on providing your organization with the products and support necessary to respond to today's threats and prepare for tomorrow's challenges.

The company's success focuses on the innovative design of its core product, the Deployable Rapid Assembly Shelter, more commonly known as DRASH. A DRASH is a quick set-up/strike soft-walled shelter specifically conceived for rapid deployment.

The company also owns the Reeves EMS brand of emergency medical products that is trusted by responders around the world and equally well-known for its quality, durability, and innovative designs.

DHS Systems is a wholly-owned subsidiary of DHS Technologies LLC. The company's headquarters are located in Orangeburg, New York, while several regional support facilities are strategically located throughout the United States. Additionally, a second major production facility is located in Huntsville, Alabama. Many of the company's products are also available to customers outside of the United States through DHS Systems International located in Hereford, England. Together, DHS Systems and DHS Systems International serve customers spanning 35 countries and across six continents.

Superior solutions would be impossible without a superior workforce behind them, and that is a key component to our success. The company employs hundreds of dedicated professionals, many who come from the same backgrounds of the major disciplines served.

All company employees work towards a common goal to keep building the best shelter solutions for our customers.

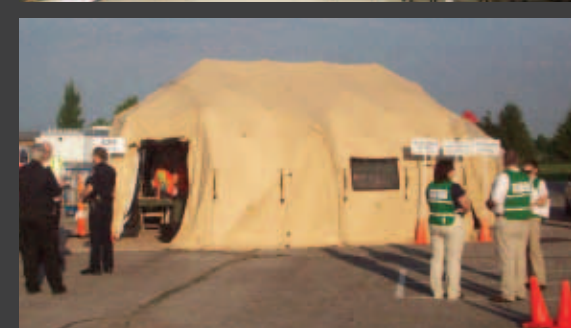

Table of Contents

DRASH	3
Intelligent Power Technology®	5
Programs	9
TMSS	11
Other	17
Applications	21
Command and Control	23
Medical	25
LSA	27
Maintenance	29
UAV	31
Satellite Support Systems	33
HRF	35
Mortuary	37
DRASH Shelters	39
C Series	43
S Series	47
XB Series	51
M Series	55
J Series	59
Specialty Shelters	63
UST Trailers	69
DC2E	73
Screen Displays	75
TUFF-TABLES™	79
IDDS™	79
Microphone System	79
Clock Systems	80
IPT Remote Monitor	80
Audio-Visual Systems	80
Accessories	83
Reeves EMS	91
Emergency Response Systems	93
Decontamination and Accessories	101
Stretchers and Immobilization	107
Product Support	113
DHS Systems International	117



DRASH®

THE WARFIGHTER'S CHOICE

DRASH's continued success is its ability to be innovative, modular, rapidly deployable, flexible and reliable. DRASH has the capabilities to integrate shelter, mobility, and a variety of utilities, information management and much more into one comprehensive package creating a total system solution.

A Total System Solution

DRASH shelter systems support numerous programs spanning all departments across the U.S. Military. Most notably, DRASH is part of the US Army's Standard Integrated Command Post System (SICPS) to provide a standardized command post to all maneuver brigades in the Army.

Beyond serving as the standard for many DoD programs, we have developed a multitude of applications to address command and control, medical, life support and maintenance facility needs.

DRASH shelters are available in six different series and include 64 different models of various lengths and widths. Shelter offerings range in size from 109 to 1,250 square feet. All shelters can interconnect

to quickly increase or decrease operational space as dictated by events on the ground.

DRASH has also developed the next innovation in energy efficient power generation. DRASH combines the proven reliability of its Utility Support Trailers to provide a complete solution that includes shelter, power and/or environmental control through its Intelligent Power Technology® (IPT) product line. It offers significant fuel savings, reduces wear and tear, and works everywhere the soldier is expected to go.

Prominent products also include Deployable Command and Control Equipment (DC2E), an advanced information integration system enabling users to extract information directly from the battlefield.

Other accessories include fuel-fired heaters, power distribution units, lighting, electrical kits, and deployment packages.

Support You Can Trust

DRASH products are supported by rigorous testing, thorough inspection, training, 24 hour technical support and rapid deliv-

ery of spare parts. To learn more about Product Support, see page 113.

Use and Deployment

DRASH has been deployed around the world as command and control centers, rapidly deployable medical treatment facilities, life support areas, maintenance and logistical support facilities.

Currently, more than 17,000 DRASH shelters and over 7,500 trailers have been deployed worldwide with U.S. and NATO forces.

DRASH has also been deployed by the armed forces of Austria, Japan, Italy, Poland, Romania, Spain, Turkey and the United Kingdom.

Our customers also include the FBI Hostage Rescue Team, Crisis Response Unit and Evidence Recovery Teams, the Department of Alcohol, Tobacco and Firearms, the National Disaster Medical System, and many government jurisdictions and other organizations around the globe.





INTELLIGENT POWER TECHNOLOGY®

Today's military is facing an energy crisis unlike any before. From unstable oil prices to the high risk of transporting fuel and to a lack of rapidly deployable equipment on the battlefield, soldiers are faced with many daunting challenges.

Soldiers cannot effectively carry out their mission without some form of tactical electrical power. Electricity is required to power everything from basic maintenance tools to sophisticated computer and information equipment, in a variety of situations and under all kinds of environmental conditions.

The U.S. Military is actively seeking solutions to address this critical mission requirement and DRASH can deliver.

The Problem

Traditionally, soldiers have relied on analog-based generators to power mobile facilities while deployed in the theater of operations. Using this conventional approach has proven problematic because these generators are only capable of providing their rated amount of electric power. Quite often, this means they must run at peak levels making them more suscep-

tible to burn outs, are prone to overload, and will shutdown when their rated output is exceeded.

Not only are analog-based generators prone to shutdowns, but operating at peak loads around the clock makes them burn exorbitant amounts of fuel, which is ineffective, costly and puts more soldiers in harm's way. Transporting fuel is complicated and dangerous. Fuel saved translates to more potential lives saved, as less convoys are needed to transfer it to remote operating bases.

These challenges call for a solution of the future but with DRASH that solution is now.

A Total System Solution

Enter DRASH Intelligent Power Technology® (IPT) – trailers that can easily be reconfigured from one location to the next with a state-of-the-art digital smart system that forms the ultimate networked power microgrid on the battlefield.

Once activated, DRASH Intelligent Power Technology® (IPT) controls each generator in the microgrid to turn "on" and "off"

based on real-time power demands and can be remotely monitored from inside your DRASH shelter system.

DRASH IPT offers significant fuel savings, reduces wear and tear and works everywhere the soldier is expected to go.

Support You Can Trust

DRASH Intelligent Power Technology® (IPT) is supported by rigorous testing, training, and 24 hour technical support.

Use and Deployment

Although relatively new, DRASH Intelligent Power Technology® (IPT) is making its way into the field and can be found supporting programs such as Terminal High Altitude Air Defense (THAAD), Harbormaster Command and Control Center (HCCC), Patriot, Battery Command Post (BCP), PM AUS Mobile Tower Systems (MOTS), and Long Endurance Multi Intelligence Vehicle (LEMV).

To learn more DRASH Intelligent Power Technology® (IPT) continue to the next page.

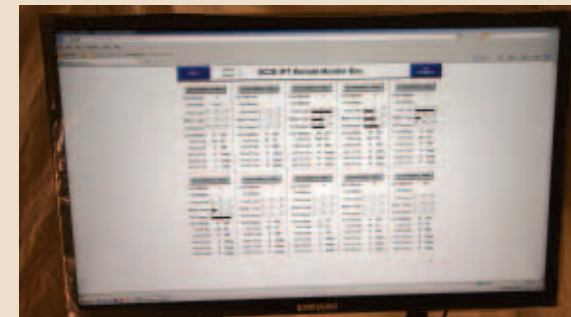
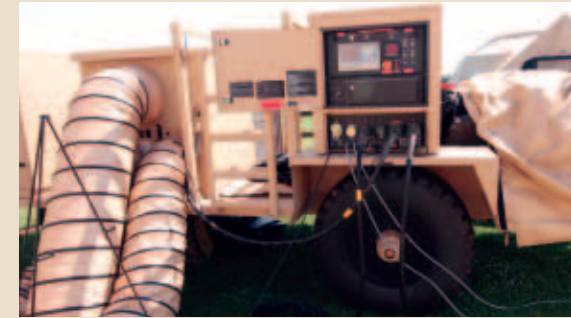



INTELLIGENT POWER TECHNOLOGY® (IPT)



DRASH Intelligent Power Technology® (IPT) enables generators to operate together and with greater efficiency greatly reducing fuel consumption, overhead and can be easily transported from one location to the next.

DRASH Intelligent Power Technology® (IPT) is delivered field ready to the soldier in a rapidly deployable package. By combining DRASH Intelligent Power Technology® (IPT) with the proven reliability of DRASH Utility Support Trailers (UST), soldiers have a highly mobile and battlefield proven platform that can easily be reconfigured from one location to the next to meet all power generation needs.

Designed to operate in the toughest terrain and easily towed behind common military vehicles, these trailers conform to established “safe to transport” criteria by the Military Transport Management Command (MTMC) as suitable for “secondary and unimproved roads” and sealift transportability. Many trailers are also certified for air transport aboard select military aircraft.

They have been tested at the Aberdeen Test Center (ATC) in Maryland and the Nevada Automatic Testing Center (NATC) to meet all U.S. Military standards for trailers.

DRASH Intelligent Power Technology® provides soldiers with the capabilities they need to prioritize and control multiple generators operating in parallel supplying only the power that is needed to meet a facility’s immediate operational requirements. Outfitted with a simple and user-friendly touch screen with robust functionality, soldiers can easily control operations from their fingertips.

IPT is designed for plug-and-play. Utilizing the latest in connectorized cabling, it instantly recognizes additional inputs and is smart enough to



automatically self-adjust without interruption as power demand changes.

This technology also features real-time system performance and diagnostics tools enabling users to monitor fuel levels, engine temperature, oil pressure, run speeds and many other essential parameters. Many of these parameters can easily be monitored remotely from inside your DRASH Shelter System using an IPT Remote Monitor (See page 80 for more information).

With the ability to remotely monitor, DRASH Intelligent Power Technology® aids soldiers in making sure that vital systems are running in the most efficient manner, and at optimum output levels all while maximizing fuel efficiency. IPT saves on maintenance costs and even extends the working life of the system itself.



DRASH Intelligent Power Technology® employs state-of-the-art safety mechanisms that also help extend the life of the system. For instance, the technology prevents the engine from starting until the required parameters and engine settings are met. This is essential because now there is much less risk of seriously damaging an engine, if for example, it’s oil or fuel is too low.

DOD BULK FUEL SUPPLY CHAIN

Transporting fuel is complicated and dangerous. Fuel saved translates to more potential lives saved, as less convoys are needed to transfer it to remote operating bases.

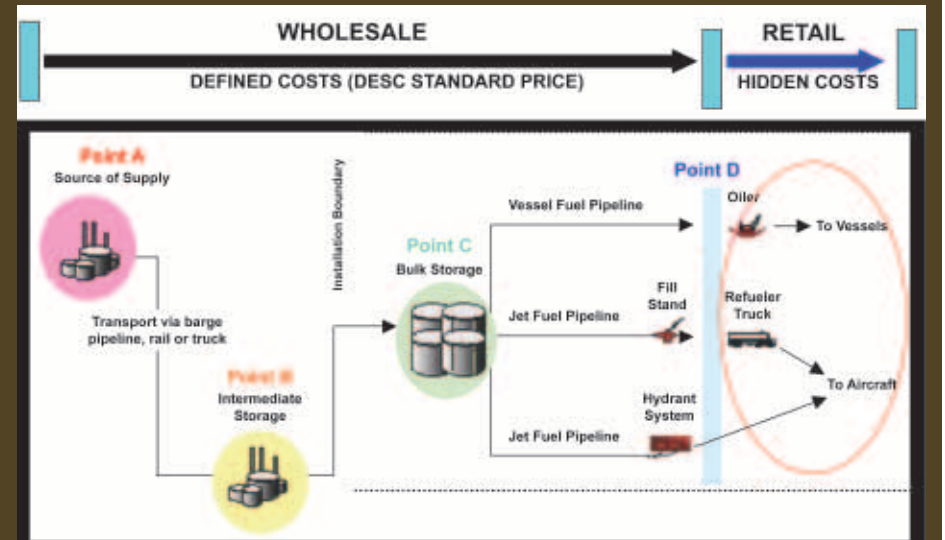

Source: Office of the Under Secretary of Defense for Acquisition, Technology, and Logistics. "Report of the Defense Science Board Task Force on DoD Energy Strategy 'More Fight - Less Fuel.'" February 2008.

Select models include a 16, 20, 26, 45 or 63 gallon (diesel or JP8) fuel tank and the capability to take fuel from any external fuel source when needed.

DRASH Intelligent Power Technology® generator offerings range from 10 to 60 kW. Additionally, they can be outfitted with a 5, 8, or 12-ton environmental control unit (ECU) to make a fully robust solution to power and provide optimal environmental control while supporting any DRASH Shelter System.

To select the most appropriate DRASH Intelligent Power Technology® (IPT) trailers for your operation, go to page 69.

Features:

- Power Management System with automatic start/stop capabilities only runs the number of generators needed to meet immediate power requirements. Load sharing ensures that the demand for power will be equally distributed among generators left running.

- Plug-and-Play capabilities allow users to connect additional IPT Trailers as needed. Simple connectorized cabling eliminates the need for any hardwiring.
- Load Shedding turns off low-priority equipment to prevent brownouts during sudden peaks in demand.
- Anti-Wet Stacking prevents engine from being clogged with unburned fuel.
- Optional Power Distribution Units (PDU) distribute power to branch circuits, utility extension

- cords and lighting fixtures throughout the facility.
- Military-Tested trailers allow for easy transport of generators through even the harshest terrain.
- Insulated shelters, such as the dual-walled DRASH shelter, can be integrated to help reduce heating and cooling loads to further reduce fuel consumption.
- Most DRASH Analog Trailers can be converted to DRASH Intelligent Power Technology®.

TOC Using Traditional Method

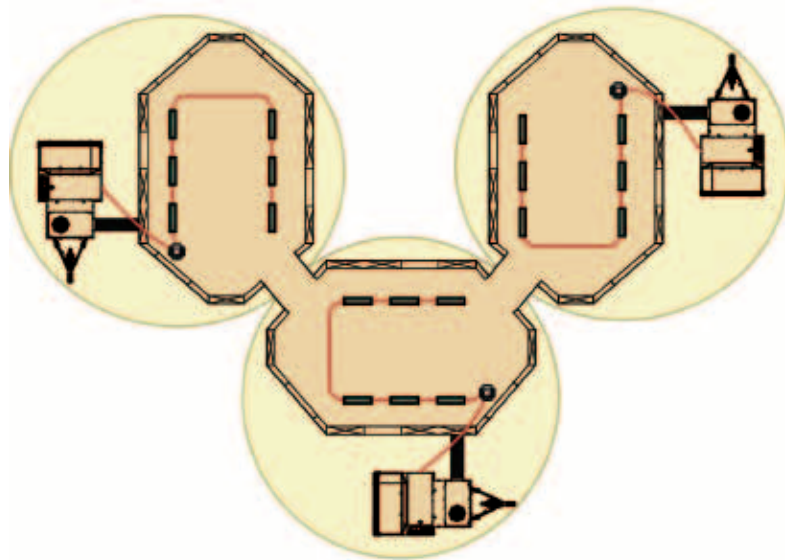

Generators running on "island mode." From a power perspective, the above tactical operations center (TOC) is comprised of three separate facilities that each require its own generator.

TOC Using DRASH Intelligent Power Technology®

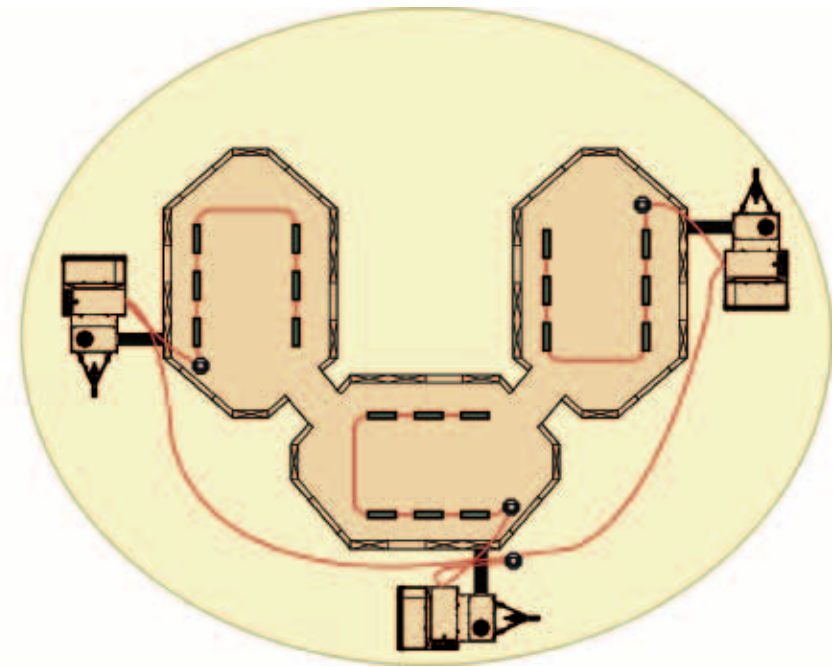

DRASH IPT allow personnel to connect generators to run together as a single power grid and reduce fuel consumption. In this TOC, all generators are working together as a single networked power microgrid.

PROGRAMS

With its tested, proven and trusted capabilities, DHS Systems quickly established itself as a reliable solutions provider for many Department of Defense (DoD) initiatives. Many of the DRASH solutions were conceived for rapid deployment via air, land or sea in response to emerging global conflicts, natural disasters, terrorist activities, humanitarian efforts or any situation requiring versatile and rapidly deployable facilities.

The first Army-wide DRASH system introduced was to support the Patriot Air and Missile Defense System. Since then, DRASH has gained increasing notoriety as part of the U.S. Army's Standard Integrated Command Post System (SICPS) to provide a standardized command post to all maneuver brigades in the Army.

As part of the Army's Standard Integrated Command Post System (SICPS), DRASH provides the Trailer Mounted Support System (TMSS) available in Medium or Large, in cooperation with Northrop Grumman Corporations Command Post Platform (CPP), to field a high mobility tactical operations center that can be rapidly deployed for command, control and

communications on the battlefield. Over 5,000 plus of these systems are currently in use across the U.S. Army and by NATO forces.

DRASH is a combat proven system whose key features of reliability, rapid deployment, and flexibility prove to be the ideal capabilities to integrate with other systems in providing a complete solution to support the warfighter. In addition to supporting the U.S. Army's SICPS program, DRASH Shelter Systems can be found supporting numerous Army, Air Force, and Marine programs. The following pages describe some of the Department of Defense (DoD) programs supported by DRASH solutions.





TMSS

As part of the U.S. Army's Standard Integrated Command Post System (SICPS) program since 2008, DHS Systems' Trailer Mounted Support System (TMSS) in cooperation with Northrop Grumman Corporation's Command Post Platform (CPP) provide high mobility tactical operations centers that can be rapidly deployed for command, control and communications on the battlefield.

Utilizing the DRASH Shelter and Utility Support Trailer design, SICPS TMSS Medium and Large Systems combine shelter, utilities, power, environmental control and tactical mobility to form a complete command operation center.

Both systems are completely towable by military vehicles and have been tested to maintain ambient temperatures in climates ranging from -50° to +131° F.

DRASH SICPS TMSS Medium

Set up within minutes, the DRASH TMSS Medium provides more than 442 square feet of usable space, includes a 5-ton ECU, and allows for the use of up to 18 kW of power.

DRASH SICPS TMSS Large

The Large System provides more than 1,120 square feet of usable space, includes a 12-ton ECU, and allows for the use of up to 33 kW of power.

Tested and Trusted

Because it is part of the Army's SICPS Program, TMSS Systems are required to meet all Army requirements for command post systems and have undergone and passed extensive testing at the Army's Aberdeen Test Center.

Currently, 5,000 DRASH SICPS TMSS Medium/ Large Systems have been fielded across the U.S. Army to Brigade Combat Teams, including units that have deployed in support of Operations Enduring Freedom and Iraqi Freedom.

TMSS Systems are available through the U.S. Army's SICPS Program or can be purchased as a shelter and trailer combination through DHS Systems. LIN numbers and NSNs are available for both systems.





TMSS MEDIUM



SICPS TMSS Medium - Green	
Noun-Nomenclature:	PU-821/T
NSNs:	6115-01-547-6713 8340-01-533-5396
LIN:	P63462
Technical Manual Number:	11-6115-742-13&P
SICPS TMSS Medium - Tan	
Noun-Nomenclature:	PU-822A/T
NSNs:	6115-01-547-6738 8340-01-533-5344
LIN:	P63462
Technical Manual Number:	11-6115-742-13&P

Trailer Features:

- 16 Gallon Fuel Tank
- 6" Channel Steel
- HMMWV Runflat Tires
- HMMWV Towable
- Slingload Capabilities

Environmental Control Unit (ECU) Features:

- 60,000 BTU/hr (cool)
- 61,000 BTU/hr (heat)
- 17,000 BTU/hr (pre heater)

Generator Features:

- 18kW (1.25 gph @ full load)

Shelter Features:

- 442 square feet
- 639 lbs.

Total System Weight:

- 4,165 lbs. (with full fuel)
- 338 lbs. (tongue weight)

Standard Components:

- MX Shelter System (1)
- HP-2C/185 Trailer (1)
- MX Side Door Connector (1)
- MX End Cap Connectors (4)
- 15' x 16" Supply Duct (1)
- 15' x 16" Return Duct (1)
- Supply and Return Auxiliary Fuel Lines (1 set)
- Power Distribution Unit (PDU) w/CD (1)
- 25 ft., 60 amp, 5 pin PDU Power Cable (1)
- Shelter Electrical Kit (1)
- Trailer Electrical Kit (1)
- DRASH 4-Light Set (1)
- Trailer ECU & Cargo Tarps (2)
- DRASH TUFF Tables (6)
- MX Shelter Field Repair Kit (1)
- Trailer Service Push Package (1)

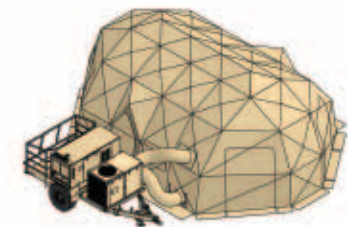
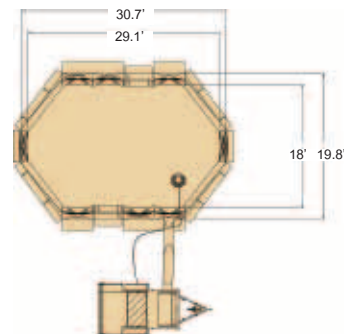

TMSS LARGE



SICPS TMSS Large - Green	
Noun-Nomenclature:	PU-823T
NSNs:	6115-01-547-8513 8340-01-537-8713
LIN:	P63394
Technical Manual Number:	11-6115-748-13&P
SICPS TMSS Large - Tan	
Noun-Nomenclature:	PU-824T
NSNs:	6115-01-547-8552 8340-01-537-8710
LIN:	P63394
Technical Manual Number:	11-6115-748-13&P

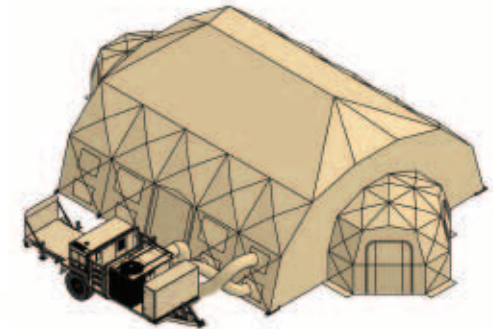

Trailer Features:

- 45 Gallon Fuel Tank
- 6" Channel Steel
- LMTV/FMTV Runflat Tires
- LMTV/FMTV Towable
- Ground Slingload Capabilities

Environmental Control Unit (ECU) Features:

- 144,000 BTU/hr (cool)
- 165,000 BTU/hr (heat)
- 17,000 BTU/hr (pre heater)

Generator Features:

- 33kW (2.65 gph @ full load)

Shelter Features:

- 1,120 square feet
- 1,600 lbs.

Total System Weight:

- 11,900 lbs. (with full fuel)
- 1,180 lbs. (tongue weight)

Standard Components:

- J Shelter System (1)
- HP-8 Trailer (1)
- Bladder and Blower System (1)
- Aluminum End Wall System (1)
- J Side Door Connector (1)
- 1XBTJ End Cap Connectors (4)
- 35' x 18" Supply Duct (1)
- 25' x 16" Return Ducts (2)
- Supply and Return Auxiliary Fuel Lines (1 set)
- Power Distribution Unit (PDU) w/CD (1)
- 50 ft., 60 amp, 5 pin PDU Power Cable (1)
- Shelter Electrical Kit (1)
- Trailer Electrical Kit (1)
- DRASH 2-Light Sets (3)
- Aluminum Tri-Fold Ladder (1)
- Trailer ECU & Cargo Tarps (2)
- DRASH TUFF Tables (8)
- J Shelter Field Repair Kit (1)
- Trailer Service Push Package (1)

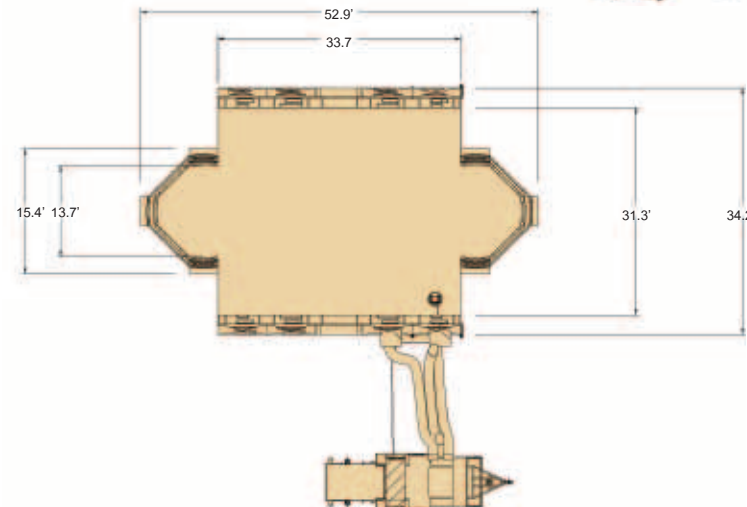

TMSS FOOTPRINTS

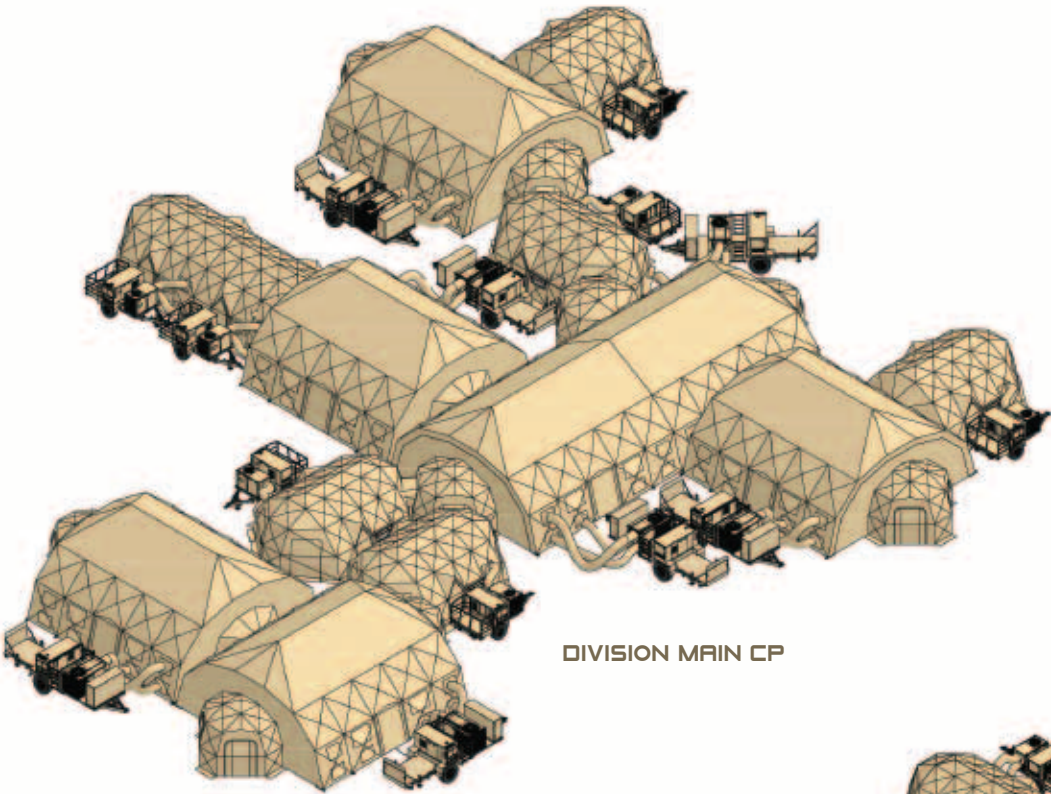

DIVISION MAIN CP

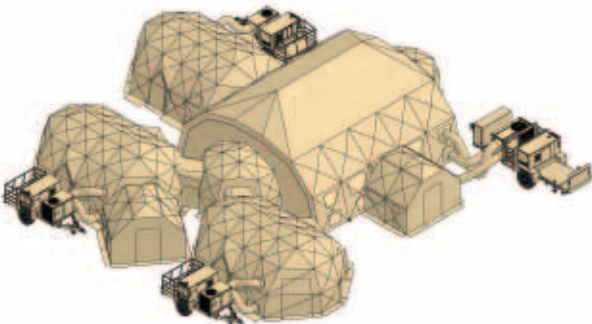

BFSB



BN

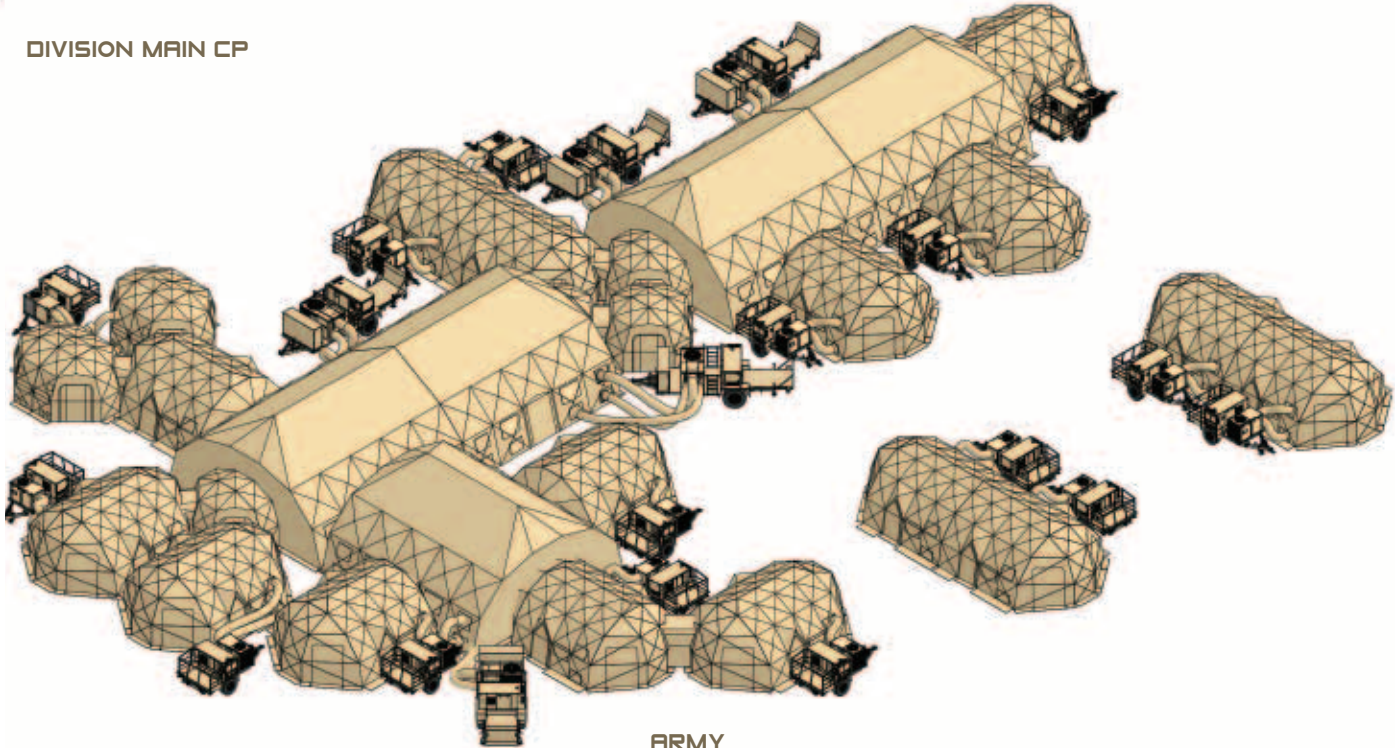

ARMY

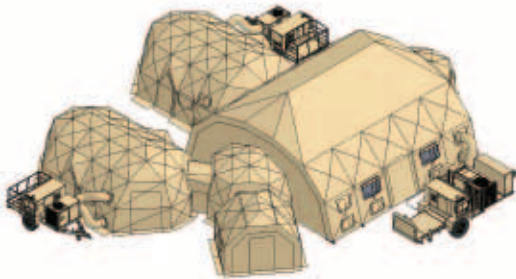

DIVISION TAC

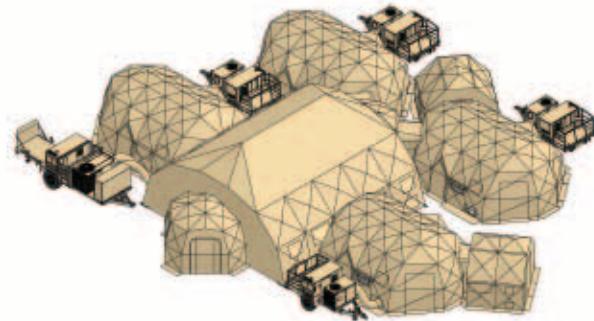

FIRES, CSB, & MED

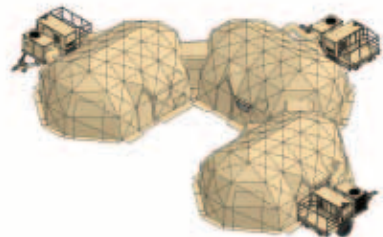

BSB

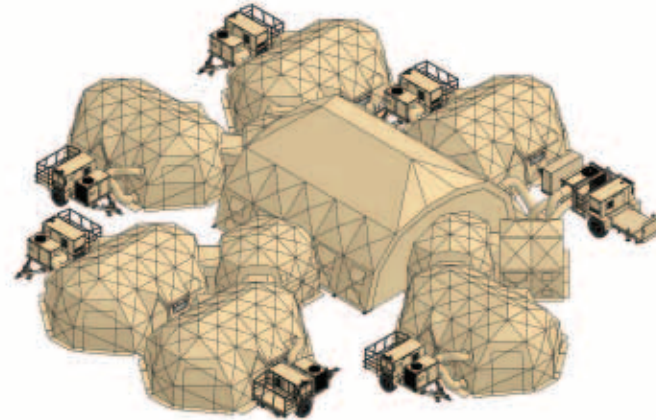

BCT, IBCT, CAB'S, SBCT, ACR

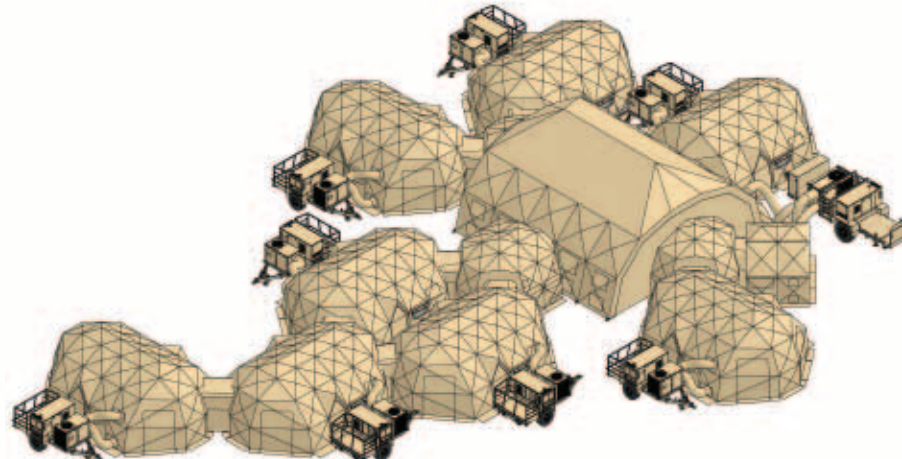

BCT, IBCT, CAB'S, SBCT, ACR WITH TAC

DIVISION MAIN CP

TMSS Medium Shelter Systems	7
TMSS Large Shelter Systems	7

BFSB

TMSS Medium Shelter Systems	3
TMSS Large Shelter Systems	1
Small Command Post	2

BN

TMSS Medium Shelter Systems	2
-----------------------------	---

ARMY

TMSS Medium Shelter Systems	16
TMSS Large Shelter Systems	5
2XB Shelter	2
HP2C/188	1

DIVISION TAC

TMSS Medium Shelter Systems	2
TMSS Large Shelter Systems	1
Small Command Post	1

BCT, IBCT, CAB'S, SBCT, ACR

TMSS Medium Shelter Systems	6
TMSS Large Shelter Systems	1
Small Command Post	1
1XBT Shelter	1

FIRES, CSB, & MED

TMSS Medium Shelter Systems	4
TMSS Large Shelter Systems	1
Small Command Post	2

BSB

TMSS Medium Shelter Systems	3
-----------------------------	---

BCT, IBCT, CAB'S, SBCT, ACR WITH TAC

TMSS Medium Shelter Systems	8
TMSS Large Shelter Systems	1
Small Command Post	1
1XBT Shelter	1

In addition to US Army's SICPS CPP, DRASH has supported other Army, Airforce and Marine (DoD) programs.

POPS-L

Psychological Operations Print System – Light

LEMV

Long Endurance Multi-intelligence Vehicle

Patriot Air and Missile Defense System

THAAD

Terminal High Altitude Area Defense

IAMD IBCS

Integrated Air and Missile Defense Battle Command System

DCGS-A

Digital Common Ground Station-Army

MPOC

Mobile Port Operations Center

ASOC

Air Support Operations Center

HCCC

Harbormaster Command and Control Center

POPS-L

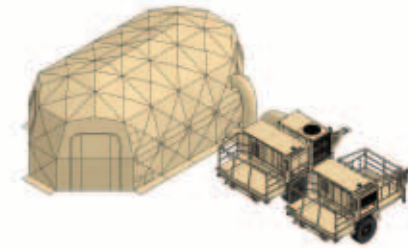

First fielded in 2008, POPS-L is a mobile printing facility used by psychological operations elements to print materials directly in the field. The facility, which provides more than 300 square feet of insulated space, can cut and box 100,000 leaflets within 24 hours.

Components:

4XB Shelter	1
HP-2C/185 Trailer	1
HP-2C1G1 Trailer	1

LEMV

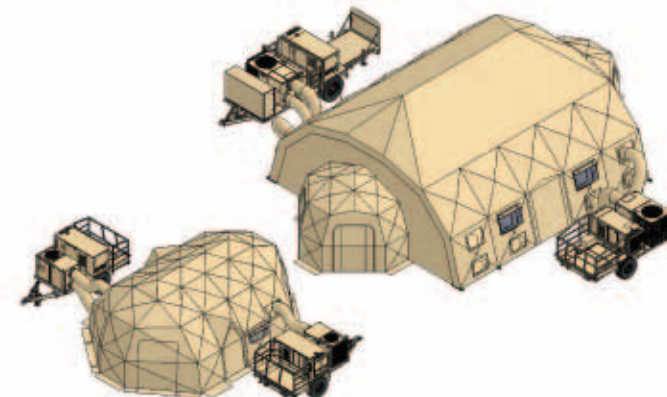

Part of the Long Endurance Multi Intelligence Vehicle (LEMV) system, DRASH supports launch, recovery and operations of one of the newest military systems shaping the future of Intelligence Surveillance and Reconnaissance.

Components:

TMSS Medium Shelter System	1
TMSS Large Shelter System	1
HP-2C185 IPT Trailer	1
HP-4/3312 IPT Trailer	1

AIR DEFENSE SYSTEMS

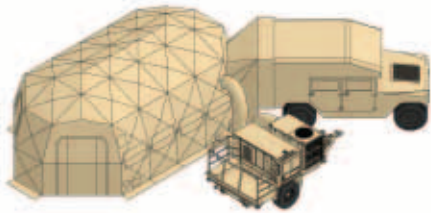

Patriot Air and Missile Defense System

Supporting the world's most advanced air and missile defense system, DRASH provides the operations area complete with power and HVAC systems for this combat proven system. The patriot provides a lethal capability to defeat threats including aircraft, tactical ballistic missiles, cruise missiles and UAVs. Deployed around the globe DRASH integration for this system has proven our equipment reliability in all weather conditions.

Components:	
4XB Shelter	1
HP-2C/188 Trailer	1
Vehicle Boot	1



THAAD

Terminal High Altitude Area Defense (THAAD), formerly Theater High Altitude Area Defense, is a United States Army system to shoot down short, medium, and intermediate ballistic missiles in their terminal phase using a hit-to-kill approach. The missile carries no warhead but relies on the kinetic energy of the impact. THAAD was designed to hit Scuds and similar weapons, but also has a limited capability against ICBMs.

Components:	
HP-2C/288 IPT Trailer	1

IAMD IBCS

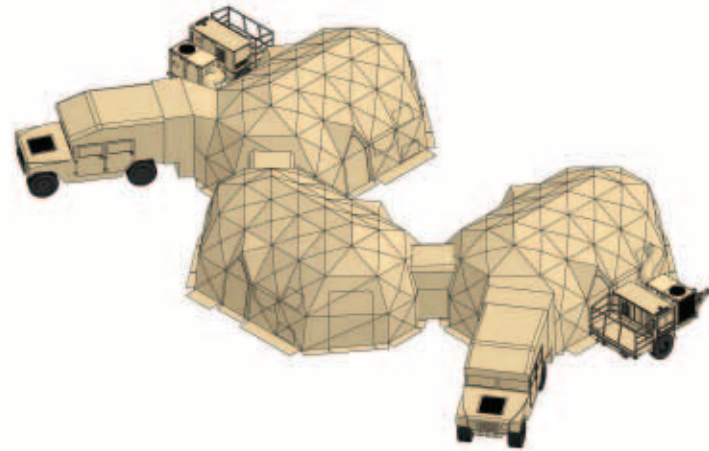

Battle command capability that will integrate current and future air and missile defense systems. The system will allow warfighters to take advantage of expanded sensor and weapon system combinations via an integrated fire control network.

Components:	
TMSS Medium Shelter System	3
Vehicle Boot	2

DCGS-A

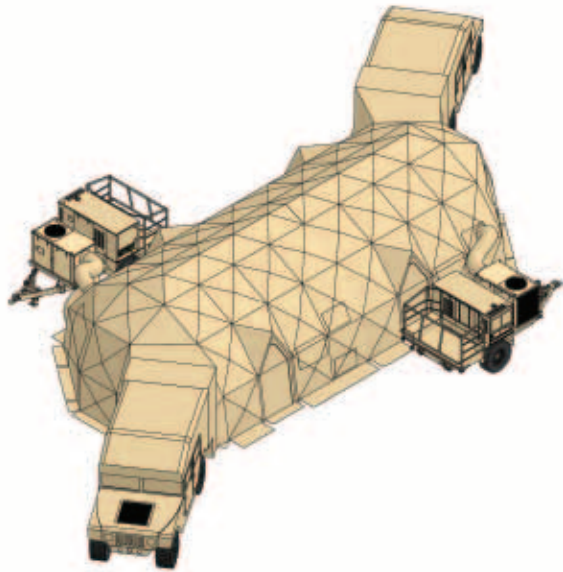

The Distributed Common Ground System (DCGS-A) is a family of fixed and deployable multi-source ground processing systems that support a range of intelligence, surveillance, and reconnaissance systems such as national and commercial satellite systems, U-2, Unmanned Aerial Vehicles (UAVs), and F-16 Theater Airborne Reconnaissance Systems (TARS). The U-2 Management Directorate at Robins Air Logistics Center provides upgrade and sustainment of operational intelligence support systems to meet DCGS operational requirements for deployable ground stations (DGS).

Components:	
TMSS Medium Shelter System	2
Vehicle Boots	2

MPOC

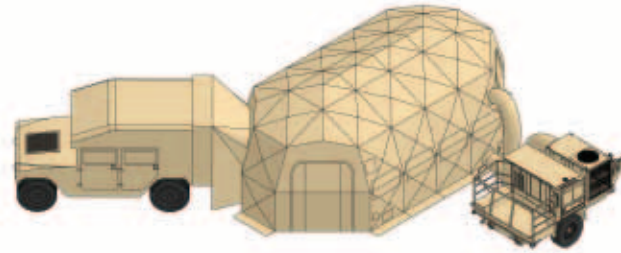

As an integral part of the U.S. Army's Surface Deployment and Distribution Command (SDDC) Mobile Port Operations Center (MPOC) capability a HMMWV-mounted C4I system the DRASH mission 4XB and HP-2C/185 is used to support port operations during small scale, short duration operations. These operations include global movement of combat units, sustainment cargo, and service member household goods.

Components:	
4XB Shelter	1
HP-2C/185 Trailer	1
Vehicle Boot	1

ASOC

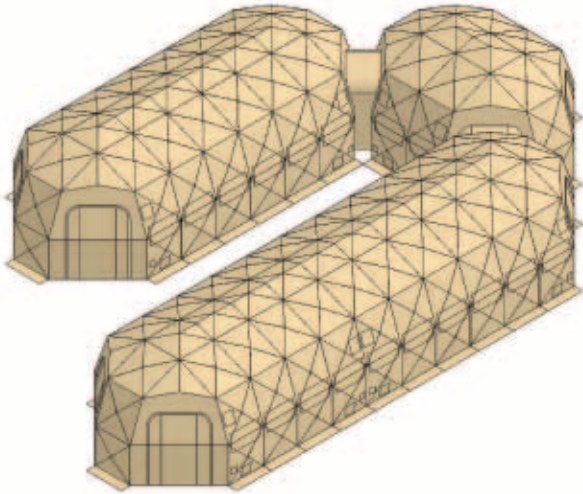

DRASH is the UTC shelter system for Air Force Air Support Operations Centers (ASOC). The ASOC mission, is the principal air control agency of the theater air control system responsible for the direction and control of air operations directly supporting the ground combat element. It processes and coordinates requests for immediate air support and coordinates air missions requiring integration with other supporting arms and ground forces. It normally collocates with the Army tactical headquarters senior fire support coordination center within the ground combat element.

DRASH provides the operations center, life support area and power for the AF Gateway program.

Components:

2XB Shelter	1
4XBT Shelter	1
6XB Shelter	1
6XBT Shelter	1

HCCC

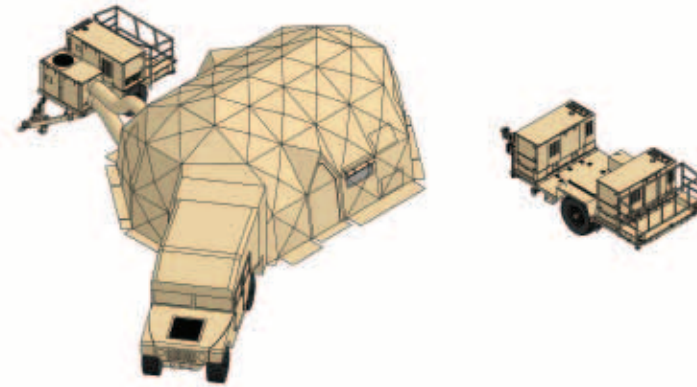

Supporting harbormasters mission to enforce regulations of a particular harbor or port to ensure the safety and security of vessels. DRASH provides turn-key shelter systems to used as fixed or mobile operational facilities.

Components:

TMSS Medium Shelter System	1
HP-6G/18 IPT Trailer	1
Vehicle Boot	1

APPLICATIONS

Although DHS Systems offers numerous solutions for many standard military programs, we realize that our customers may have a variety of additional requirements that need to be met. Our team routinely develops new solutions to address a range of missions and requirements pertaining to today's dynamic work environments.

DHS Systems has the capabilities and resources to carefully research and fully develop new applications to address sheltering problems. With the majority of the company's field representatives having served in the military or as first-responders, the company is well-positioned to deliver appropriate applications, and has years of collective knowledge and experience to stand behind their products.

With their vast knowledge and understanding of the needs of today's warfighter and first-responder, DRASH experts have developed several footprints, which answer the call for more compelling solutions. So long as our customers keep demanding the best shelter solutions, then DHS Systems solution providers will con-

tinue to develop new applications anticipating your needs for years to come.

DRASH is a combat proven system whose key features of reliability, rapid deployment, and flexibility prove to be the ideal capabilities to integrate with other systems in providing a complete solution to support the warfighter and first-responder. The following pages describe many of the DRASH applications currently available in greater detail.

DRASH Applications

- Command and Control
- Medical
- Life Support Areas
- Maintenance
- UAV Shelter Systems
- Satellite Support Systems
- Homeland Response Force
- Mortuary





COMMAND AND CONTROL



Establishing command and control requires access to sophisticated equipment that can capture information from multiple sources and diverse platforms. Unfortunately, conditions are not always optimal for the smooth operation of sensitive technical equipment. Personnel also need a command center that can be deployed wherever and whenever needed, making it a flexible asset on the battlefield.

With a 25 year history of supplying the military with rugged and reliable command posts and tactical operations centers, tested and trusted DRASH Command and Control Systems provide the ultimate solution to establishing command and control anywhere you need to be.

- Modular design allows shelters to be used alone or connected together to increase the operational footprint.
- DRASH Deployable Command and Control Equipment (DC2E) combines multiple feeds of information onto a single display system, allowing for the management of assets in real-time. For more information please see page 73.
- Fully integrated electrical and lighting system provides ample lighting and power regardless of external conditions.
- Heating and cooling capabilities allow for optimal environmental conditions even in extreme temperatures.

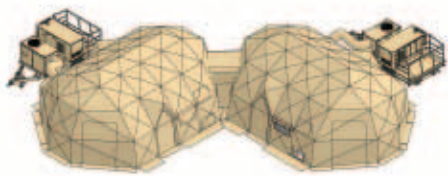

BCT TAC CP

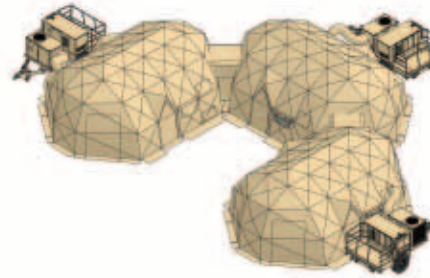

BSB CP

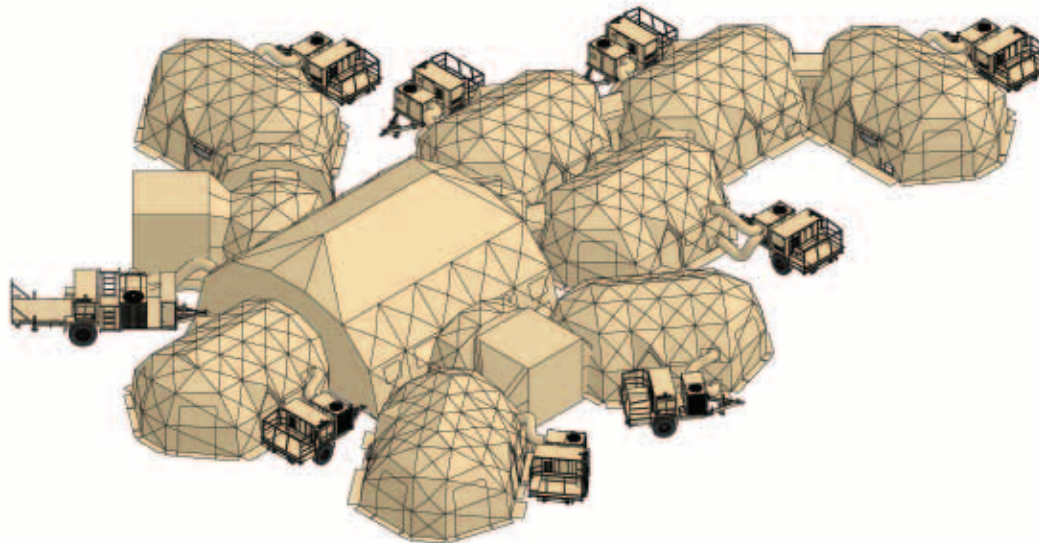

BCT MAIN CP WITH TAC CP

BCT TAC CP

Shelters
MX 2

Trailers
HP-2C/185 2

Entire structure can be deployed by 4-6 personnel in under 30 minutes.

BSB CP

Shelters
MX 3

Trailers
HP-2C/185 3

Entire structure can be deployed by 4-6 personnel in under 60 minutes.

BCT MAIN CP WITH TAC CP

Shelters
MX 8
J 1
1XBT 1
1XBTJ 1
VBS (1XBI) 2

Trailers
HP-2C/185 8
HP-8 1

Entire structure can be deployed by 10-12 personnel in under 3 hours.



MEDICAL



For nearly 25 years, DRASH shelter systems have been fielded to U.S. Army Forward Surgical Teams (FSTs) as mobile medical facilities that can be deployed with troops directly in the combat zone. The shelters' rapid setup/strike design has allowed medical personnel to set up within minutes of arrival and provide the wounded with immediate access to life-saving procedures.

Now, customers who choose DRASH have the added protection of XYTEX 500™. Embedded inside the shelter fabric, it offers 99.99% protection against microbes, mold, mildew and fungus. XYTEX 500™ is permanent and does not fade over time providing a more aseptic or sterile like environment for patients and healthcare workers. (For more information see page 42.)

- Modular design allows for Level 1, Level 2 and Level 3 Care, can be used with DEPMEDS support equipment and connects to all DEPMEDS shelters through the use of a custom connector.
- Isolation capabilities allow medical personnel to treat victims of biocontamination without contracting the infection themselves.
- Decontamination capabilities ensure optimal readiness during any situation.
- Dual cover design allows for a clean, aseptic work environment.



BATTALION AID STATION

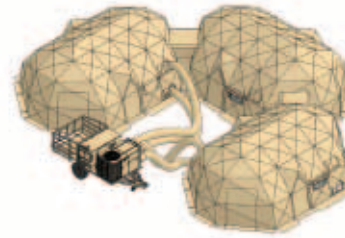

FST

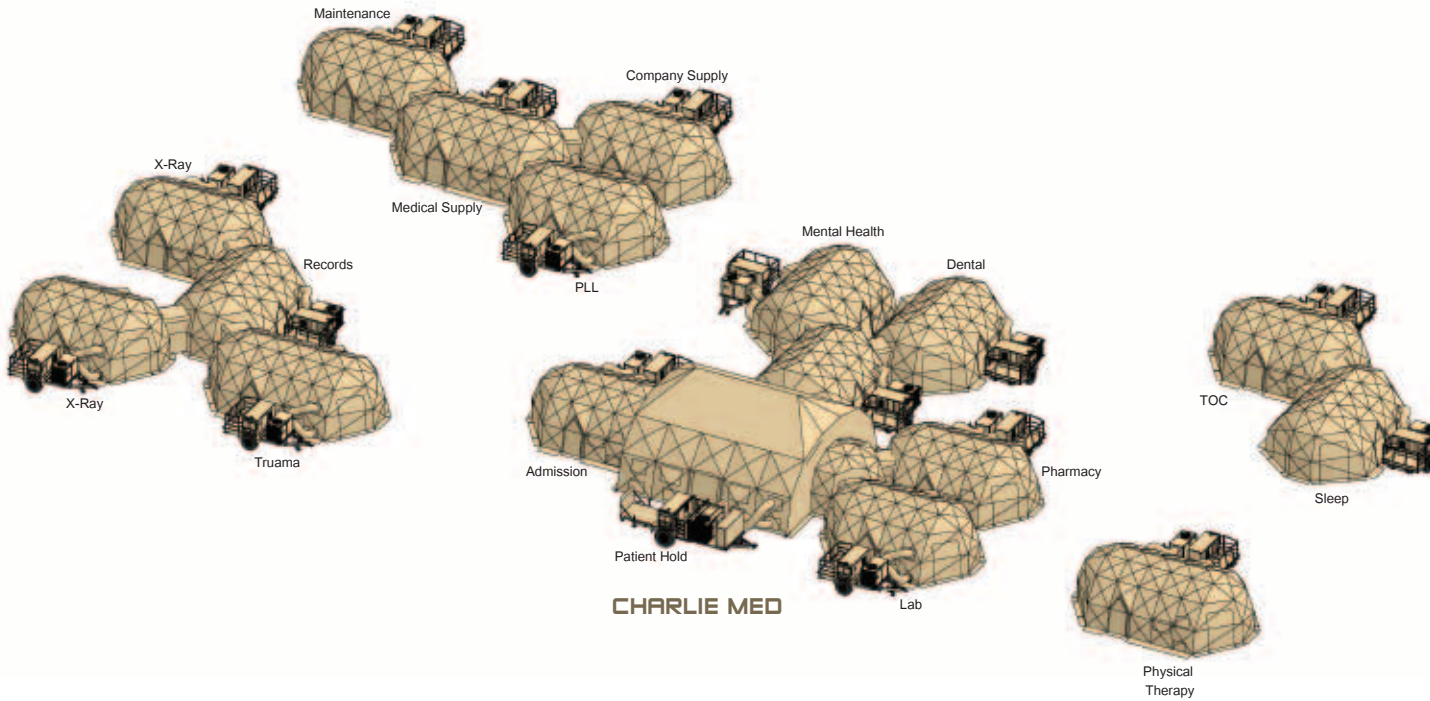

CHARLIE MED

BATTALION AID STATION

Shelters
MX 1

Trailers
HP-2C/185 1

Entire structure can be deployed by 4 personnel in under 30 minutes.

FST

Shelters
MX 3

Trailers
HP-2C/185 1

Entire structure can be deployed by 6 personnel in under 45 minutes.

CHARLIE MED

Shelters
MX 15
MX5 2
J 1

Trailers
HP-2C/185 17
HP-8 1



LIFE SUPPORT AREAS



In today's military environment, frequency of deployment, extreme environmental conditions, and the onset of both natural and manmade disasters, have increased the need for temporary life support facilities often for days, and sometimes weeks, at a time. Establishing the right kind of temporary shelter can ultimately effect the success of a mission.

DRASH Life Support Areas provide users with agreeable living conditions to ensure they are well-rested and have a place to go to after work. They also keep out the weather while also providing a quick setup/strike, modular facility that can grow with the size of the mission and offer electricity, environmental control, and ample living space.

- Modular design allows shelters to be used alone or connected together to create mobile hygiene systems, medical treatment facilities, sleep areas or dining facilities.
- Wide interior widths of up to 31.5 feet allow for enough space for cots, dining tables or recreational components.
- Built in screened windows and doors allow for natural air circulation and keep insects out.
- Hygiene facilities provide shower and cleaning amenities in multiple types of environments.

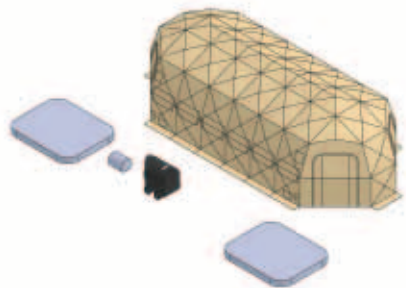

MOBILE HYGIENE SYSTEM

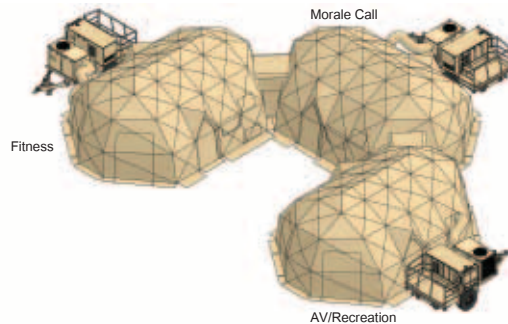

MWR FACILITY

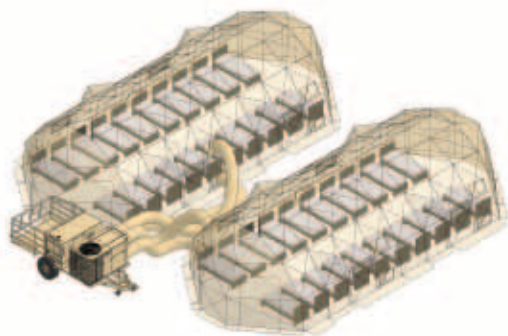

SLEEP AREA

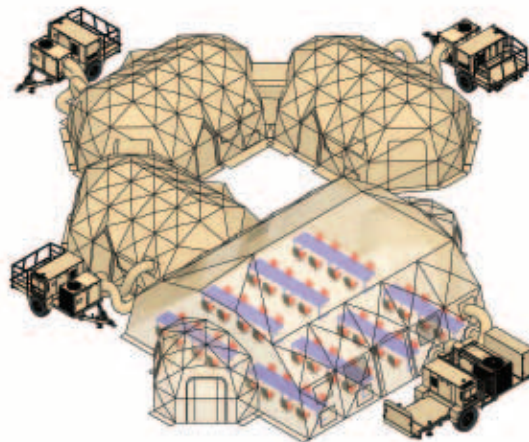

DINING FACILITY

MOBILE HYGIENE SYSTEM

Shelters	
6XB	1
Ancillary Equipment	
G2 Water Heater	1
Diesel Pump	1
F. Water Bladder	1
G. Water Bladder	1

Entire structure can be deployed by 6 personnel in under 30 minutes.

MWR FACILITY

Shelters	
MX	3
Trailers	
HP-2C/185	3

Entire structure can be deployed by 4 personnel in under 60 minutes.

SLEEP AREA

Shelters	
M*	2
Trailers	
HP-4/3312	1

** Each shelter has a sleep capacity of 20-25 personnel.*

Entire structure can be deployed by 4 personnel in under 60 minutes.

DINING FACILITY

Shelters	
MX	3
1XBTJ	2
J	1
Trailers	
HP2C/185	3
HP/8	1

Entire structure can be deployed by 6 personnel in under 90 minutes.



MAINTENANCE



In military science, it is well known that maintaining troops' supply lines and equipment is one of the most crucial elements of military strategy. An armed force without food, fuel, vehicles, and ammunition is essentially powerless. To aid in the maintenance of these items, it is essential that quick setup/strike shelters are available to protect both equipment and maintenance personnel from the elements.

DRASH shelters are designed to fulfill multiple maintenance and logistical support functions, including those of warehousing supplies in the field, staging of large vehicles or providing space to perform vehicle maintenance work.

- Modular design allows shelters to be used alone or connected together to create large logistical support facilities or warehouses.
- Shelter doors can be closed tightly against the elements and maintain a consistent temperature to provide a cool, dry storage space for all of your field supplies.
- Maintenance doors available to accommodate HMWWV, FMTV or UAV vehicles.
- Fully-integrated electrical and lighting systems provide ample lighting and power regardless of external conditions.

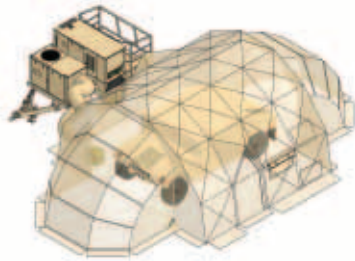

MEDIUM MAINTENANCE FACILITY

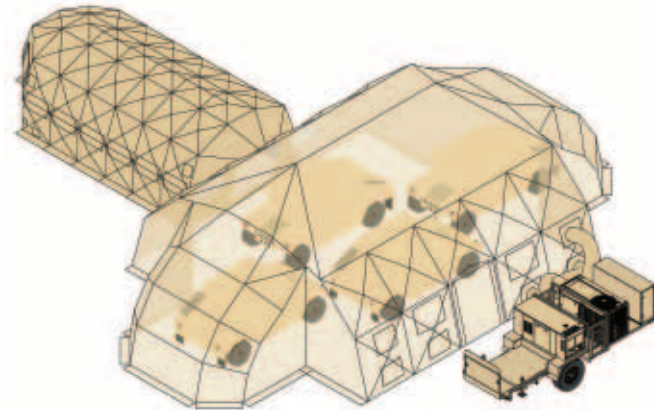

LARGE MAINTENANCE FACILITY

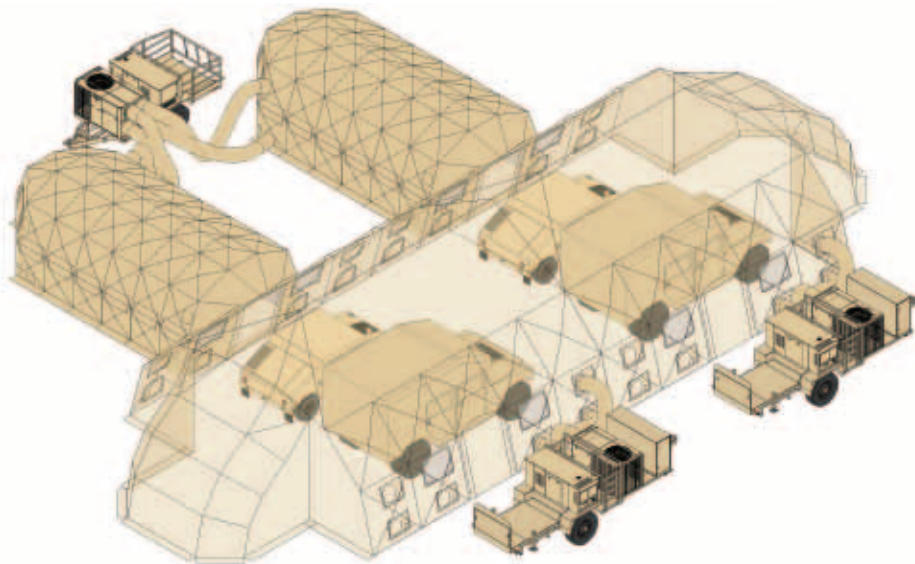

MODULAR MAINTENANCE FACILITY

MEDIUM MAINTENANCE FACILITY

Shelters
MX5 1

Trailers
HP-2C/185 1

Entire structure can be deployed by 6 personnel in 45 minutes.

LARGE MAINTENANCE FACILITY

Shelters
J 1
6XBT 1

Trailers
HP-8 1

Entire structure can be deployed by 6-8 personnel in 90 minutes.

MODULAR MAINTENANCE FACILITY

Shelters
J 2
6XBT 2

Trailers
HP-4/3312 1
HP-8 2

Entire structure can be deployed by 6 personnel in under 120 minutes.



UNMANNED AERIAL VEHICLE SHELTER SYSTEMS



Unmanned Aerial Vehicles (UAV) are playing a greater role than ever before in the theater of operations. From reconnaissance to the tracking and delivery of munitions, UAVs provide today's combatant commanders with the resources they need to accomplish their mission.

DRASH UAV Systems help facilitate the operation and maintenance of these vehicles by of-

fering a quick erect/strike system that is rugged, reliable and combat proven to protect both equipment and personnel from the elements. The systems are designed to fulfill multiple maintenance functions, including staging and servicing vehicles during operations or warehousing supplies, as well as to provide the space needed to carry out flight operations from the field.

- Modular design allows shelters to be used alone or connected together to create larger logistical support or flight operations areas.
- Turn-key system includes an environmentally-controlled work area, power and lighting to provide users with a mission ready, trailer mounted system requiring a minimal logistical footprint.
- Multiple, various-sized footprints are available to accommodate the full range of UAV systems currently in use with U.S. Military and NATO forces.
- Tested and proven during training missions held at U.S. Military installation, Fort Bragg.

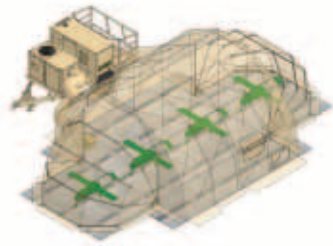

MEDIUM UAV SHELTER SYSTEM

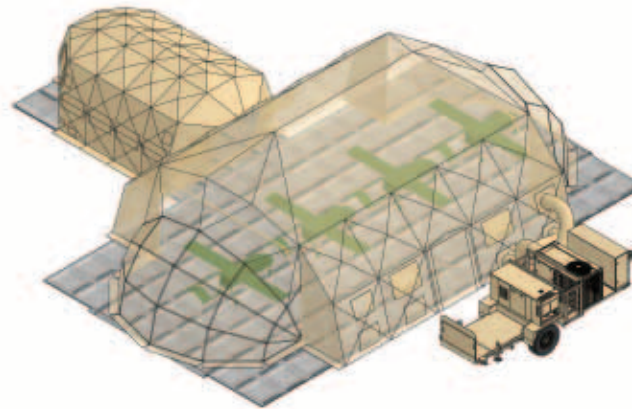

LARGE UAV SHELTER SYSTEM

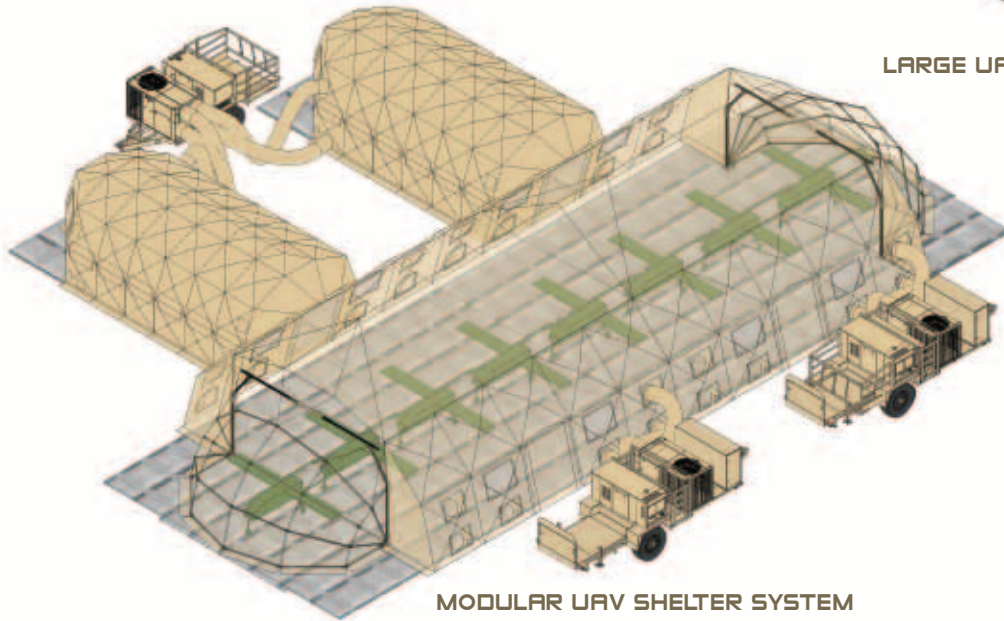

MODULAR UAV SHELTER SYSTEM

MEDIUM UAV SHELTER SYSTEM

Shelters
MX 1

Trailers
HP2C/185 1

Entire structure can be deployed by 4 personnel in under 30 minutes.

LARGE UAV SHELTER SYSTEM

Shelters
J 1
4XBT 1

Trailers
HP-8 1

Entire structure can be deployed by 6 personnel in under 90 minutes.

MODULAR UAV SHELTER SYSTEM

Shelters
J 2
6XBT 2

Trailers
HP-4/3312 1
HP-8 2

Entire structure can be deployed by 6 personnel in under 120 minutes.



SATELLITE SUPPORT SYSTEMS



DRASH Satellite Support Systems join satellite communications technology and rugged and reliable DRASH shelters to form a complete integrated shelter system providing personnel with ample workspace, cover and concealment.

Utilizing the DRASH Satellite Support System, which can easily be set up by two (2) personnel in less than 10 minutes, users can connect the vari-

ous communication platforms in use today, such as the Satellite Transport Terminal (STT) and Warfighter Information Network-Tactical (WIN-T), to any DRASH shelter - providing a larger, more effective work area from which they can operate communications equipment regardless of harsh weather and environmental conditions.

- Shelter ensures convenient and tactical workspace for personnel providing cover and concealment.
- Accommodates a range of platforms, including STT, WIN-T, JNN, Standard Integrated Command Post System (SICPS), Integrated Platform Solutions (IPS) Logistics Support, and Air Defense Airspace Management (ADAM) Cell.

- Unique booting system provides a light-tight fabric connection between a vehicle and any DRASH shelter.
- Shelter support equipment, including heaters and power distribution units, is also available.

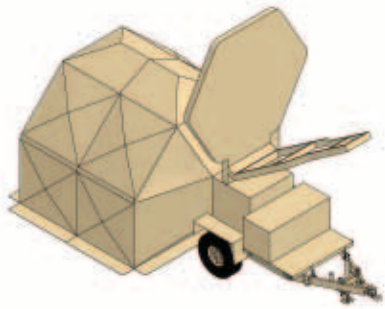

STT V1 AND V2

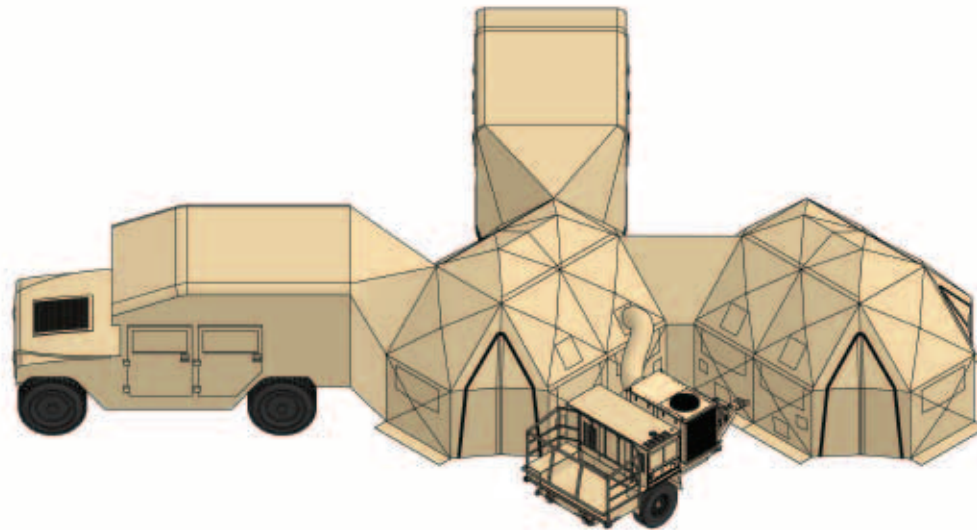

JOINT NETWORK NODE (JNN) /
SINGLE SHELTER SWITCH (SSS)

STT V1 AND V2

Shelters
Small Command Post 2 1

**JOINT NETWORK NODE (JNN) /
SINGLE SHELTER SWITCH (SSS)**

Shelters
2S 1

Trailers
HP2C/185 1



HOMELAND RESPONSE FORCE



From command and control to decontamination to search and extraction, Homeland Response Forces (HRFs) must be ready to complete a wide range of operations when disaster strikes. As a result, they need facilities that are as versatile and reliable as they are.

DRASH shelters allow HRFs to establish a fully capable consequence management system that

provides the operational flexibility they need using equipment that has already been fielded as part of the U.S. Army's Standard Integrated Command Post System (SICPS). Available in various sizes and models and with a full line of accompanying support equipment, DRASH ensures that HRFs have the proper workspace to complete any mission.

Featuring a quick erect design, DRASH shelters allow HRFs to establish a complete Joint Operations Area (JOA) within hours of arrival at the event scene.

As depicted in the diagram on the right, DRASH set-up time for the JOA beats HRF deployment timelines by a full 8 hours.

- Decontamination, residual monitoring, medical triage and Tactical Command Post (TAC) facilities are operational in 1 hour.
- The Tactical Operations Center (TOC) and Administrative-Logistics Operations Center (ALOC) is then established providing a full Initial Response Force (IRF) within 4 hours upon arrival.

JOINT OPERATIONS AREA

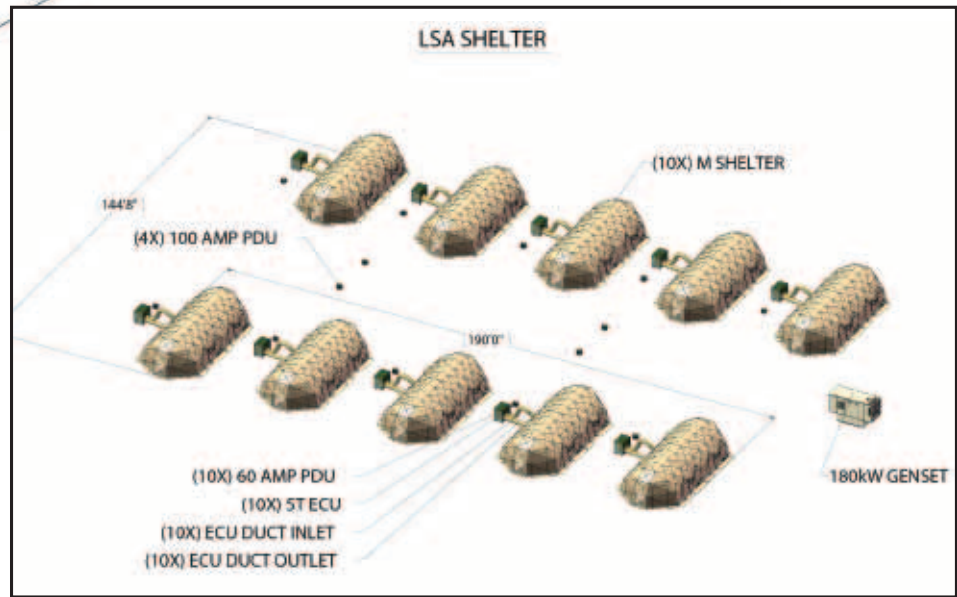
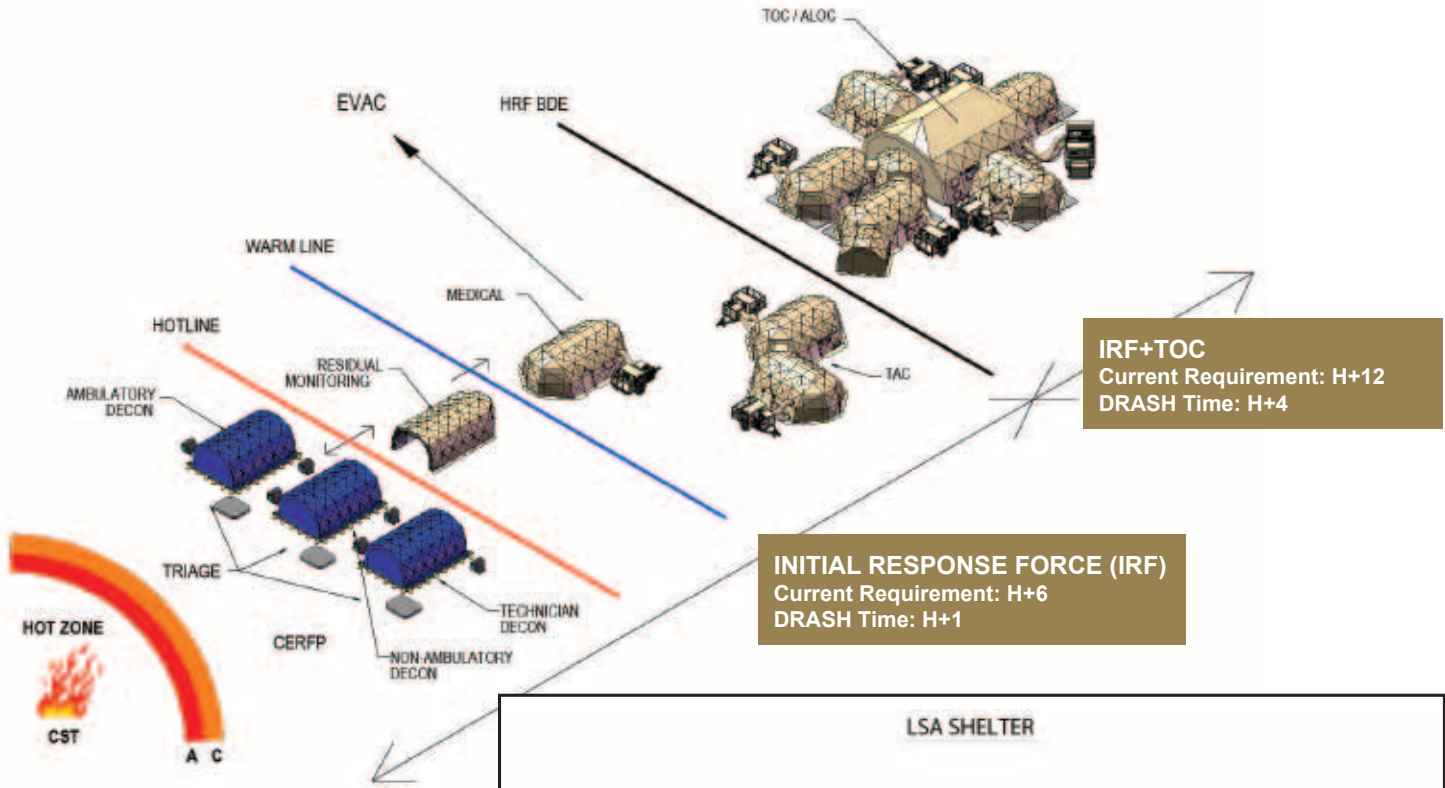

Using the entire scope of DRASH systems to include; quick erect shelters, USTs, deployable command and control equipment and decontamination equipment, an HRF can establish all the facilities they need to form a complete Joint Operations Area. A life support area can be established to support personnel remaining at the incident site for an extended period of time.

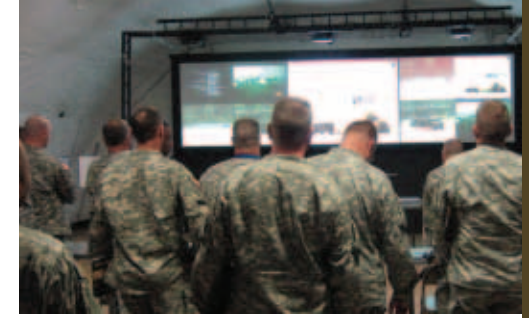

MORTUARY



Receiving and handling remains is an important responsibility that ensures proper identification and processing of victims of armed conflict or natural or manmade disasters. Mortuary Affairs units need to be able to set up minutes from an incident in order to properly identify victims and prepare them for burial. To preserve the victims before interment, a Mortuary Affairs infrastructure needs

to be able to maintain a consistent interior temperature, even in desert weather conditions.

DRASH systems can assist in establishing a scalable collection point for high intensity conflicts or mass fatality disasters. Able to be fully operational within minutes of arrival, DRASH systems enable Mortuary Affairs personnel to establish a Mortu-

ary Affairs Collection Point (MACP), Mortuary Affairs Decontamination Collection Point (MADCP) or a Theater Mortuary Evacuation Point (TMEP) where and when it is needed most. Additionally, DRASH shelter systems come with a complete power package that ensures optimum operations even in extreme temperature conditions.

Infrastructure options include:

Roller systems, sinks, surgical tables, decon, medical lighting, medical equipment, climate controlled remains storage, bodybags, and field desks.

MORTUARY AFFAIRS/MASS CASUALTY SYSTEM

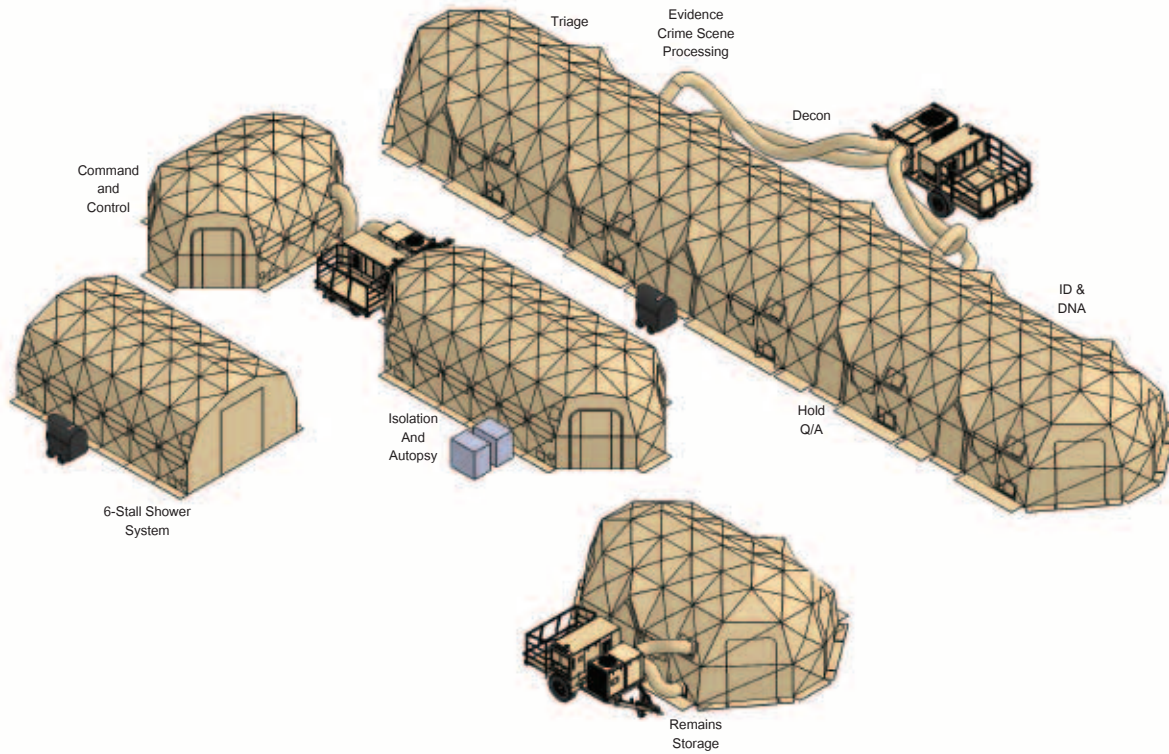

MORTUARY AFFAIRS/MASS CASUALTY SYSTEM

Shelters

M	2
MX5 Center Cection	1
Patient Isolation System	1
Mobile Hygiene System	1
3XB	1
MX	1

Trailers

HP2C/185	2
HP4/3312	1



DRASH SHELTERS

The Deployable Rapid Assembly Shelter, more commonly known in the field as DRASH, forms the foundation of the company's core product line. A DRASH is a quick setup/strike soft-walled shelter specifically conceived for rapid deployment via air, land or sea in response to emerging global conflicts, natural disasters, terrorist activities, humanitarian efforts or any situation requiring a mobile facilities and has been part of military training and combat operation for more than 25 years.

A DRASH shelter is considered to be the most proven, tested, and trusted shelter in use by the military today worldwide. DRASH engineers and project managers have spent years perfecting the technology used to construct the shelter selecting the best fabric and using the latest composites with flex strength 270 percent greater than aluminum.

What sets a DRASH shelter aside from the competition is its innovative design and construction. The shelter is designed in such a way to minimize assembly time and to withstand the harshest conditions in the worst environments.

The patented DRASH shelter design does not require site preparation or extensive training. Shelters can be set up in minutes with minimal manpower and without the use of special tools or dealing with loose parts that could get lost or broken.

DRASH shelters have been put through the most rigorous tests at the Aberdeen Test (ATC) in Maryland and meet all Mil-Standard requirements for soft-walled shelters. Shelter covers are fire retardant, mildew resistant, water repellent, abrasion resistant and ultraviolet resistant. Every DRASH shelter is meticulously inspected by highly trained quality control specialists.

Although DRASH offers many standard DoD program solutions and a variety of their own unique line of applications, we understand that successful shelter solutions do not always follow a one size fits all approach.

That's why DRASH is standing by to partner with you in creating a customizable solution that fit your mission specific requirements. DRASH has the capability

to seamlessly integrate numerous shelter models into a total system solution according to your unique specifications.

No matter what your constraints, DRASH can tailor solutions that meet your budget and are mindful of your timeframe. If needed, DRASH encourages customers to visit their website at www.drash.com/vtap and design their own footprint.





SHELTER DESIGN

The DRASH design is comprised of a frame with two pre-attached covers and integrated flooring. This means that setting up a DRASH shelter does not require special tools or dealing with loose parts. Additionally, its easy-to-use strut and hub configuration allows it to be set up within minutes of arriving at location.

In this design, pairs of struts are made from an advanced composite material called Titanite®. Titanite® has 270 percent more flex strength than aluminum for the same diameter and cross sectional area. This means that it will bend but not break under pressure. The struts connect to the framework at points called hubs. These hubs allow the shelter to be pushed up and out with no locking devices for quick set up or take down. A double layer of high-tech fabric called XYTEX 500™ provides natural insulation that keeps out the winter cold and summer heat in addition to

providing protection against microbes. The specially-coated fabric is fire retardant, mildew resistant and water repellent, and is resistant to abrasion and ultraviolet rays.

DRASH C, S, XB, M and J Series Shelters are categorized according to width, length and design — with the C being the smallest at 109 square feet and the J being the largest at 1,250 square feet. Shelters can be interconnected to increase or decrease an overall structure's footprint.

In addition to the 64 standard DRASH shelter models, a line of specialty shelters has been created that includes an Arctic Tent, Satellite Antenna Shelter, Self Enclosed Annex Lobby and EMI Shelter. For more information on these shelters please turn to page 63.



C Series

Interior Length
9.7 - 25.6'
Exterior Length
10.5 - 27.4'

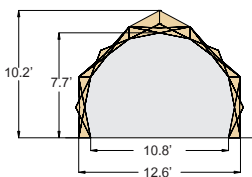

S Series

Interior Length Range
5 - 36.5'
Exterior Length Range
5 - 38.5'

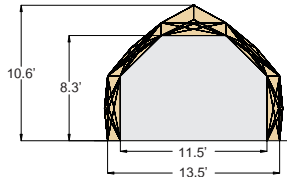

XB Series

Interior Length Range
4 - 33.6'
Exterior Length Range
4 - 35.3'

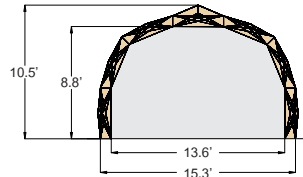

M Series

Interior Length Range
29.1 - 47.7'
Exterior Length Range
30.7 - 46'

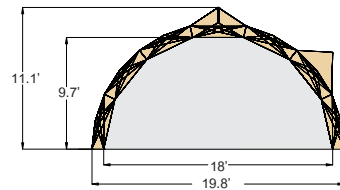

J Series

Interior Length Range
51.4 - 58.9'
Exterior Length Range
52.9 - 58.9'

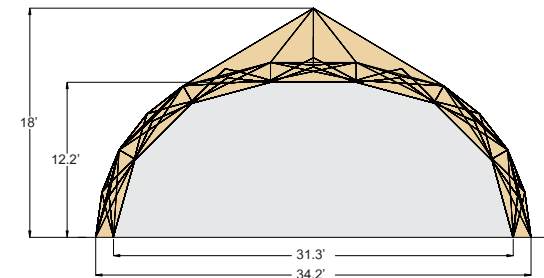

XYTEX 500™

DRASH is the most technologically-advanced line of shelter systems available today, incorporating multiple patents and constantly improving and integrating technologies into its design to enhance its capabilities.

Now, DRASH shelters come with the added protection of XYTEX 500™. Embedded inside the shelter fabric, XYTEX 500™ offers 99.99% protection against microbes. The nanotechnology consists of a microscopic bed of nano size spikes that lie in wait to puncture the cell walls of invading microbes, killing them upon contact.

Unlike other common antimicrobials, XYTEX 500™ is not a temporary disinfectant and will not dissipate over time. Instead, XYTEX 500™ is permanent for the life of the

fabric. Even better, the technology is environmentally friendly and EPA registered.

Designed primarily for a medical application to provide patients and healthcare workers with an additional safeguard, XYTEX 500™ can enhance and improve the environment for command and control and life support areas as well.

XYTEX 500™ is also fire retardant, water repellent and resistant to abrasion and ultra violet rays. It will also guard against mold, mildew and fungus enabling the shelter to stay cleaner between scheduled routine maintenance and when in storage after a deployment.

Please visit www.drash.com/xytex500 for more information.

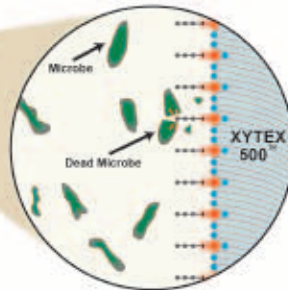
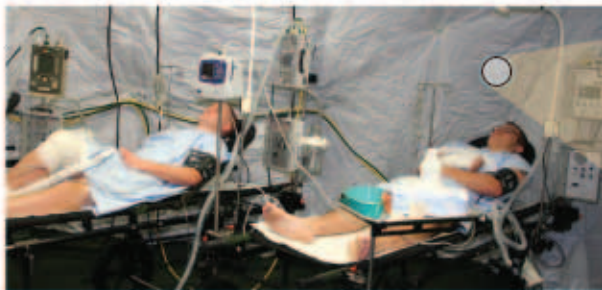

SHELTER TESTING



DRASH is the most technologically-advanced line of shelter systems available today, incorporating multiple patents and undergoing thorough testing for its shelters, trailers and support equipment.

DRASH shelters have been tested for rain, wind, temperature, durability, blackout and snowload at the Aberdeen Test Center (ATC) in Maryland and

meet all U.S. Mil-Standard requirements for soft-walled shelters.

DRASH utility support trailers have undergone rigorous testing at both ATC and the Nevada Automotive Testing Center (NATC), and have met military criteria during environmental, transportability, electromagnetic interference (EMI) and electromagnetic pulse (EMP) testing.

DRASH DURABILITY TESTING					
Test Criteria/Shelter Series	C Series	S Series	XB Series	M Series	J Series
Rain Able to withstand two inches per hour of free falling and blowing rain for 30 minutes without intrusion of water into the shelter.	PASSED	PASSED	PASSED	PASSED	PASSED
Wind Able to withstand a steady wind of 55 mph with gusts up to 65 mph.	PASSED	PASSED	PASSED	PASSED	PASSED
Temperature Able to sustain inside ambient temperatures of +40°F to +87°F within an hour when subjected to extreme high and low temperature ranges of -50°F to +131°F.	PASSED	PASSED	PASSED	PASSED	PASSED
Durability Able to withstand a minimum of 50 erect/strike cycles without structural damage.	PASSED	PASSED	PASSED	PASSED	PASSED
Blackout Interior shelter lights not visible during ingress/egress within 100 meters with the naked eye, or within 300 meters with night vision goggles.	PASSED	PASSED	PASSED	PASSED	PASSED
Snowload Able to withstand 10lbs/sq. ft. of snow load for 12 hours without damage using All Weather Kit.	PASSED	PASSED	PASSED	PASSED	PASSED

Complete results based on tests conducted at U.S. Army Aberdeen Test Center from 2004 to 2006. Test results relevant for all shelters manufactured with XYTEX® covers and Titanite® struts. Test results available upon request.

C SERIES

DRASH C Series Shelters have an **interior width of 11 feet (3.5 meters)** and an **interior height of 7.7 feet (2.3 meters)**, and come in three model sizes in four basic variants, **providing from 109 to 272 square feet (10.1 – 25.2 sq. m.) of usable space** depending on the model and the variant.

Its quick setup/strike design allows it to be set up or taken down by as few as two to four personnel in under 15 minutes. The shelter is simply offloaded and positioned, lifted and spread, then pushed up and secured. A power port, duct port and optional stove pipe port make the shelter usable in all climates and weather conditions.

C Series Shelters pack down to less than 2 percent of deployed size for easy transport.

Included Components:

- Complete Shelter
- Integrated Flooring
- Steel Stake Set
- Repair Kit
- Push Poles
- Transport Bag

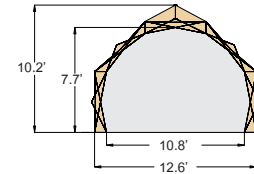



C SERIES

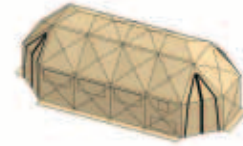
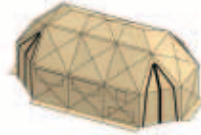

			2C	3C	4C
Part Numbers	Green		1010046	1010571	1010575
	Tan		1010047	1010572	1010576
NSNs	Green		Pending	Pending	Pending
	Tan		Pending	Pending	Pending
Length	Interior	ft.	16.5	21.1	25.6
		m.	4.9	6.4	7.8
	Exterior	ft.	18.1	22.9	27.4
		m.	5.5	6.9	8.4
Usable Area	sq. ft.		164	218	272
	sq. m.		15.2	20.3	25.3
Total Weight	lbs.		251	305	352
	kg.		114	138	160
Packed Dimensions	in.		64 x 28 x 30	64 x 33 x 31	64 x 35 x 32
	cm.		163 x 71 x 76	163 x 84 x 79	163 x 89 x 81
Packed Volume	cu. ft.		31.1	37.9	41.5
	cu. m.		0.9	1.1	1.2

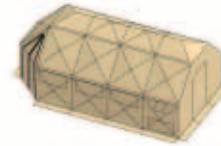
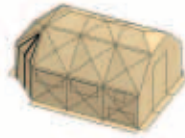

			2CT	3CT	4CT
Part Numbers	Green		1010569	1010573	1010577
	Tan		1010570	1010574	1010578
NSNs	Green		Pending	Pending	Pending
	Tan		Pending	Pending	Pending
Length	Interior	ft.	13.1	17.9	22.2
		m.	3.9	5.3	6.8
	Exterior	ft.	13.9	18.7	23.1
		m.	4.2	5.6	7.0
Usable Area	sq. ft.		136	190	244
	sq. m.		12.6	17.7	22.7
Total Weight	lbs.		221	275	322
	kg.		100	125	146
Packed Dimensions	in.		64 x 27 x 29	64 x 31 x 30	64 x 33 x 31
	cm.		163 x 69 x 74	163 x 79 x 76	163 x 84 x 79
Packed Volume	cu. ft.		29	34.4	37.9
	cu. m.		0.8	1.0	1.1

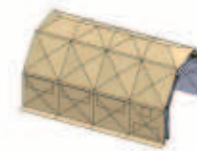

			2CI	3CI	4CI
Part Numbers	Green		1010897	1010899	1010901
	Tan		1010898	1010900	1010902
NSNs	Green		Pending	Pending	Pending
	Tan		Pending	Pending	Pending
Length	Interior	ft.	9.7	14.6	19.4
		m.	3.0	4.3	5.9
	Exterior	ft.	9.7	14.6	19.4
		m.	3.0	4.3	5.9
Usable Area	sq. ft.		109	161	214
	sq. m.		10.1	15.0	19.9
Total Weight	lbs.		175	230	277
	kg.		79.4	104	126
Packed Dimensions	in.		62 x 21 x 28	64 x 29 x 28	64 x 31 x 28
	cm.		156 x 54 x 71	163 x 74 x 71	163 x 79 x 71
Packed Volume	cu. ft.		20.9	30.1	32.2
	cu. m.		0.6	0.9	0.9

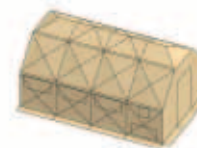
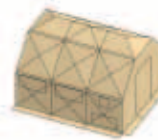

			Small Command Post 2	Small Command Post 3	Small Command Post 4
Part Numbers	Green		SH202-0001G	1010889	1010891
	Tan		SH202-0001T	1010890	1010892
NSNs	Green		Pending	Pending	Pending
	Tan		Pending	Pending	Pending
Length	Interior	ft.	9.7	14.6	19.4
		m.	3.0	4.3	5.9
	Exterior	ft.	9.7	14.6	19.4
		m.	3.0	4.3	5.9
Usable Area	sq. ft.		109	161	214
	sq. m.		10.1	15.0	19.9
Total Weight	lbs.		215	275	335
	kg.		97.5	124.7	152
Packed Dimensions	in.		62 x 21 x 28	64 x 29 x 28	64 x 31 x 28
	cm.		156 x 54 x 71	163 x 74 x 71	163 x 79 x 71
Packed Volume	cu. ft.		20.9	30.1	32.2
	cu. m.		0.6	0.9	0.9

S SERIES

S Series Shelters have an **interior width of 11.5 feet (3.5 meters)** and an **interior height of 8.3 (2.5 meters)**, and come in six model sizes in three basic variants, **providing from 112 to 402 square feet (10.4 – 37.7 sq. m.) of usable space** depending on the model and the variant.

All S Series Shelters can be easily set up within 15 minutes of arriving at location by as few as four to six people and can be taken down just as quickly. S Series Shelters do not require any assembly in the field, nor do they require any special equipment for either setting up or striking.

S Series Shelters pack down to less than 2 percent of deployed size for easy transport.

Included Components:

- Complete Shelter
- Integrated Flooring
- Steel Stake Set
- Repair Kit
- Push Poles
- Transport Bag

A custom-made T Boot is included for ST Model Shelters to fit the client's vehicle or ISO Container.

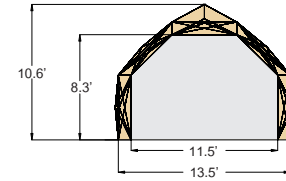



S SERIES



		1S	2S	3S	4S	5S	6S	
Part Numbers	Green	00100G	00200G	00300G	00400G	00500G	00600G	
	Tan	00100T	00200T	00300T	00400T	00500T	00600T	
NSNs	Green	8340-01-459-4337	8340-01-439-8421	8340-01-439-8416	8340-01-439-8425	8340-01-439-8949	8340-01-439-8957	
	Tan	8340-01-459-4324	8340-01-395-3976	8340-01-439-9119	8340-01-395-3986	8340-01-439-8947	8340-01-395-7853	
Length	Interior	ft.	11.5	16.5	21.5	26.5	31.5	
		m.	3.5	5	6.6	8.1	9.6	
	Exterior	ft.	13.5	18.5	23.5	28.5	33.5	38.5
		m.	4.1	5.6	7.2	8.7	10.2	11.7
Usable Area	sq. ft.	112	168.6	226.1	283.6	341.1	402	
	sq. m.	10.4	15.6	21	26.3	31.7	37.7	
Total Weight	lbs.	246	313	381	440	502	575	
	kg.	112	142	173	200	228	261	
Packed Dimensions	in.	66 x 24 x 29	66 x 28 x 30	66 x 33 x 31	66 x 35 x 31.5	66 x 36 x 32	66 x 37 x 33	
	cm.	168 x 61 x 74	168 x 71 x 76	168 x 84 x 79	168 x 89 x 80	168 x 91 x 81	168 x 94 x 84	
Packed Volume	cu. ft.	26.6	32.1	39.1	42.1	44	46.6	
	cu. m.	0.8	0.9	1.1	1.2	1.3	1.3	

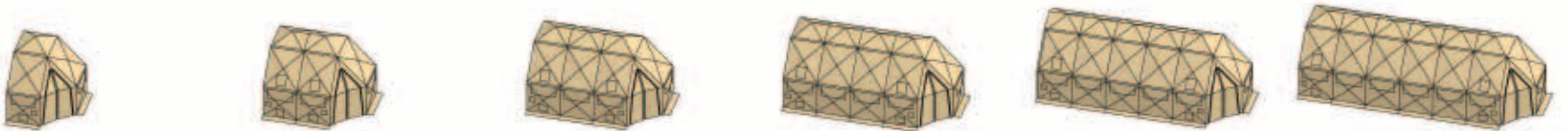

		1ST	2ST	3ST	4ST	5ST	6ST	
Part Numbers	Green	0010TG	0020TG	0030TG	0040TG	0050TG	0060TG	
	Tan	0010TT	0020TT	0030TT	0040TT	0050TT	0060TT	
NSNs	Green	8340-01-514-0520	8340-01-439-8981	8340-01-439-9004	8340-01-457-1590	8340-01-457-2182	8340-01-457-2206	
	Tan	8340-01-514-0521	8340-01-439-9123	8340-01-439-8996	8340-01-457-1595	8340-01-457-2204	8340-01-457-2209	
Length	Interior	ft.	8.3	13.3	18.3	23.3	28.3	
		m.	2.5	4.1	5.6	7.1	8.6	
	Exterior	ft.	9.3	14.3	19.3	24.3	29.3	34.3
		m.	2.8	4.4	5.9	7.4	8.9	10.5
Usable Area	sq. ft.	84.3	141.8	199.3	256.8	314.3	371.8	
	sq. m.	7.8	13.2	18.5	23.8	29.2	34.5	
Total Weight	lbs.	209	276	344	403	450	523	
	kg.	95	125	156	183	204	237	
Packed Dimensions	in.	66 x 23 x 28	66 x 27 x 29	66 x 31 x 30	66 x 33 x 30.5	66 x 34 x 31	66 x 35 x 32	
	cm.	168 x 48 x 71	168 x 69 x 74	168 x 79 x 76	168 x 84 x 77	168 x 86 x 79	168 x 89 x 81	
Packed Volume	cu. ft.	24.6	29.9	35.5	38.4	40.3	42.8	
	cu. m.	0.7	0.9	1.0	1.1	1.1	1.2	



		1SI	2SI	3SI	4SI	5SI	6SI	
Part Numbers	Green	0010IG	0020IG	0030IG	0040IG	0050IG	0060IG	
	Tan	0010IT	0020IT	0030IT	0040IT	0050IT	0060IT	
NSNs	Green	Pending	Pending	Pending	Pending	Pending	Pending	
	Tan	Pending	Pending	Pending	Pending	Pending	Pending	
Length	Interior	ft.	5	10	15	20	25	30
		m.	1.5	3.1	4.6	6.1	7.6	9.1
	Exterior	ft.	5	10	15	20	25	30
		m.	1.5	3.1	4.6	6.1	7.6	9.1
Usable Area	sq. ft.	57.5	115	172	230	287.5	345	
	sq. m.	5.3	10.7	16	21.4	26.7	32	
Total Weight	lbs.	152	219	287	346	393	466	
	kg.	68.9	99.2	130	156.7	178	211	
Packed Dimensions	in.	66 x 22 x 26	66 x 26 x 27	66 x 29 x 28	66 x 31 x 28	66 x 32 x 29	66 x 33 x 30	
	cm.	168 x 56 x 66	168 x 66 x 69	168 x 74 x 71	168 x 79 x 71	168 x 81 x 74	168 x 84 x 76	
Packed Volume	cu. ft.	21.9	26.8	31	33.2	35.4	37.8	
	cu. m.	0.6	0.8	0.9	0.9	1.0	1.1	



XB SERIES

XB Series Shelters have an **interior width of 13.6 feet (4.2 meters)** and an **interior height of 8.8 feet (2.7 meters)**, and come in six model sizes in three basic variants, **providing 140.4 to 413.4 square feet (13 to 38.4 meters) of usable space** depending on the model and the variant.

All XB Series Shelters can be easily set up within 15 minutes of arriving at location by only four to six people and can be taken down just as quickly. XB Series Shelters do not require any assembly in the field, nor do they require any special equipment for either setting up or striking. Simply offload and position, lift and spread, push up, and secure.

XB Series Shelters pack down to less than 2 percent of deployed size for easy transport.

Included Components:

- Complete Shelter
- Integrated Flooring
- Steel Stake Set
- Repair Kit
- Vestibule Curtains
- Push Poles
- Transport Bag

A custom-made T Boot is included for XBT Model Shelters to fit the client's vehicle or ISO Container.

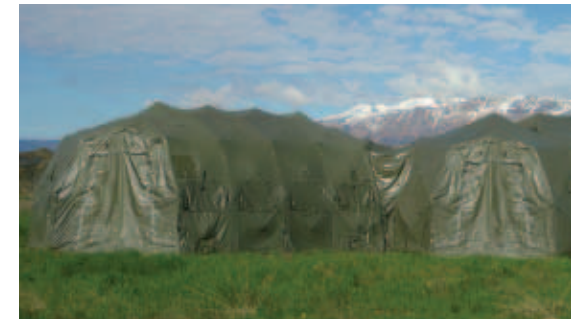
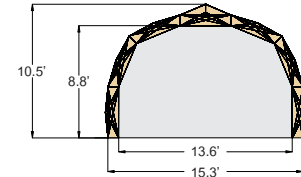



XB SERIES



		1XB	2XB	3XB	4XB	5XB	6XB	
Part Numbers	Green	100100G	100200G	100300G	100400G	100500G	100600G	
	Tan	100100T	100200T	100300T	100400T	100500T	100600T	
NSNs	Green	8340-01-514-0514	8340-01-475-2871	8340-01-475-2973	8340-01-462-6736	8340-01-475-3110	8340-01-475-3075	
	Tan	8340-01-514-0515	8340-01-475-2880	8340-01-475-2975	8340-01-462-6735	8340-01-475-3074	8340-01-475-3077	
Length	Interior	ft.	13.6	17.6	21.6	25.6	29.6	33.6
		m.	4.1	5.4	6.6	7.8	9	10.2
	Exterior	ft.	15.3	19.3	23.3	27.3	31.3	35.3
		m.	4.7	5.9	7.1	8.3	9.5	10.8
Usable Area	sq. ft.	140.4	195	249	304.2	358.8	413.4	
	sq. m.	13	18	23	28.2	33.3	38.4	
Total Weight	lbs.	243	323	403	483	563	644	
	kg.	110.2	146.5	182.8	219.1	255.4	292.1	
Packed Dimensions	in.	52 x 36.5 x 25	52 x 38.8 x 26.5	52 x 41 x 27.8	52 x 42.9 x 29	52 x 46.4 x 30.3	52 x 49.9 x 31.5	
	cm.	132 x 93 x 64	132 x 98 x 67	132 x 104 x 70	132 x 109 x 74	132 x 118 x 77	132 x 127 x 80	
Packed Volume	cu. ft.	27.5	30.9	34	37.4	42.2	47.3	
	cu. m.	0.8	0.9	1.0	1.1	1.2	1.3	



		1XBT	2XBT	3XBT	4XBT	5XBT	6XBT	
Part Numbers	Green	10010TG	10020TG	10030TG	10040TG	10050TG	10060TG	
	Tan	10010TT	10020TT	10030TT	10040TT	10050TT	10060TT	
NSNs	Green	8340-01-514-0516	8340-01-475-3078	8340-01-475-3083	8340-01-475-3118	8340-01-475-3127	8340-01-475-3136	
	Tan	8340-01-514-0517	8340-01-475-3080	8340-01-475-3115	8340-01-475-3120	8340-01-475-3131	8340-01-475-3142	
Length	Interior	ft.	8.8	12.8	16.8	20.8	24.8	28.8
		m.	2.7	3.9	5.1	6.3	7.6	8.8
	Exterior	ft.	9.6	13.6	17.6	21.6	25.6	29.6
		m.	2.9	4.1	5.4	6.6	7.9	9
Usable Area	sq. ft.	97.7	152.3	206.9	261.5	316.1	370.7	
	sq. m.	9	14	19.2	24.3	29.4	34.4	
Total Weight	lbs.	171	251	331	411	491	571	
	kg.	77.6	113.9	150.1	186.4	222.7	259	
Packed Dimensions	in.	52 x 33 x 22	52 x 35.8 x 23	52 x 38 x 25.5	52 x 40 x 26	52 x 43 x 27.5	52 x 47 x 28	
	cm.	132 x 86 x 61	132 x 91 x 58	132 x 96 x 65	132 x 102 x 66	132 x 109 x 70	132 x 119 x 71	
Packed Volume	cu. ft.	21.9	27.7	29.2	31.3	35.6	39.6	
	cu. m.	0.6	0.7	0.8	0.9	1.0	1.1	



			1XBI	2XBI	3XBI	4XBI	5XBI	6XBI
Part Numbers	Green		10010IG	10020IG	10030IG	10040IG	10050IG	10060IG
	Tan		10010IT	10020IT	10030IT	10040IT	10050IT	10060IT
NSNs	Green		Pending	Pending	Pending	Pending	Pending	Pending
	Tan		Pending	Pending	Pending	Pending	Pending	Pending
Length	Interior	ft.	4	8	12	16	20	24
		m.	1.2	2.4	3.7	4.9	6.1	7.3
	Exterior	ft.	4	8	12	16	20	24
		m.	1.2	2.4	3.7	4.9	6.1	7.3
Usable Area	sq. ft.	55	109.6	164.2	218.8	273.4	328	
	sq. m.	5.1	10.1	15.3	20.3	25.4	30.5	
Total Weight	lbs.	98	178	258	338	418	498	
	kg.	44.5	80.7	117	153.3	189.6	225.9	
Packed Dimensions	in.	52 x 31 x 20	52 x 32 x 21	52 x 35 x 22	52 x 37 x 23	52 x 40 x 24	52 x 44 x 25	
	cm.	132 x 79 x 51	132 x 81 x 53	132 x 89 x 56	132 x 94 x 58	132 x 102 x 61	132 x 112 x 64	
Packed Volume	cu. ft.	18.7	20.2	23.2	25.6	28.9	33.1	
	cu. m.	0.5	0.6	0.7	0.7	0.8	0.9	



M SERIES

M Series Shelters provide an **interior width of 18 feet (5.5 meters)** and an **interior height of 9.7 feet (3 meters)** and come in three basic models in varying lengths. Additionally, M Series Shelters can be lengthened to increase an operating area by removing the shelters' end caps and adding additional center sections.

All M Shelters can be easily set up within minutes of arriving at location by four to six people and can be taken down just as quickly. M Series Shelters do not require any special equipment for either erecting or striking. Simply offload and position, lift and spread, push up, attach end caps, and secure.

M Series Shelters pack down to less than 2 percent of deployed size for easy transport.

Included Components:

- Center Sections
- End Caps
- Windows
- Doors
- Fabric Flooring
- Steel Stake Pin Set
- Repair Kit
- Push Poles
- Transport Bag

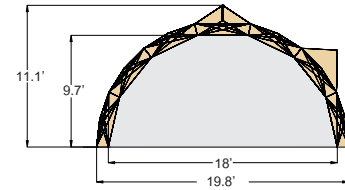



M SERIES

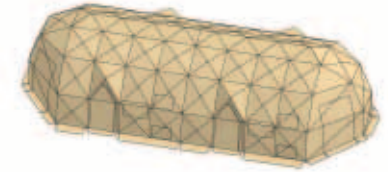
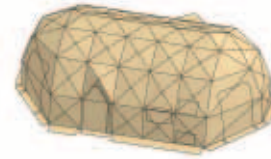
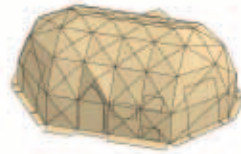

		MX	MX5	M	
Part Numbers	Green	MXA2000G	SH201-0601G	MA100100	
	Tan	MXA2000T	SH201-0601T	MA100500	
NSNs	Green	8340-01-538-1822	8340-01-540-7566	8340-01-533-1654	
	Tan	8340-01-538-1823	8340-01-540-7592	8340-01-533-1653	
Length	Exterior	ft. / m.	30.7 / 9.4	34.9 / 10.6	47.7 / 14.5
	Interior	ft. / m.	29.1 / 8.9	33.3 / 10.1	46 / 14
Usable Area	Entire Shelter	sq. ft. / sq. m.	442 / 41	519 / 48.2	748 / 69.5
	Center Section Only*	sq. ft. / sq. m.	306 / 28	383 / 36	612 / 57
	Individual Endcap**	sq. ft. / sq. m.	68 / 6.3	68 / 6.3	68 / 6.3
Total Weight	Entire Shelter	lbs. / kg.	625 / 283.5	724 / 328.4	1,115 / 506
	Center Section Only*	lbs. / kg.	490 / 222.3	590 / 267.3	980 / 443.9
	Individual Endcap**	lbs. / kg.	67 / 30.4	67 / 30.4	67 / 30.4
Packed Dimensions	Center Section Only*	in. / cm.	56 x 44.5 x 31.5 / 142 x 113 x 80	56 x 44.5 x 33.5 / 142 x 113 x 85.1	56 x 44.5 x 31.5 / 142 x 113 x 80
	Individual Endcap**	in. / cm.	51 x 23 x 23 / 130 x 58 x 58	51 x 23 x 23 / 130 x 58 x 58	51 x 23 x 23 / 130 x 58 x 58
Packed Volume	Center Section Only*	cu. ft. / cu. m.	45.4 / 1.3	48.3 / 1.4	45.4 / 1.3
	Individual Endcap**	cu. ft. / cu. m.	13.6 / 0.4	13.6 / 0.4	13.6 / 0.4

*The DRASH M Shelter includes two center sections, which are stored in two separate packages. Measurements reflect individual packages.

**Two per shelter. Maintenance doors also available.



M Maintenance Door (Optional)

Part Number: SH533-0801G (Green), SH533-0801T (Tan)

An M Maintenance Door is a clam shell retractable entry point that can be connected to the truncated end of any M Series Shelter allowing smaller UAVs and smaller vehicles access into the shelter for maintenance or storage purposes.

Usable Area	sq. ft.	90
	sq. m.	8.4
Total Weight	lb.	132
	kg.	62.6
Width	ft.	11.1
	m.	3.4
Height	ft.	8.7
	m.	2.7

J SERIES

The DRASH J Series Shelter is the largest of DRASH shelters, offering **1,250 square feet (116 square meters) of usable space.**

The J can be transported using the DRASH HP-J4 Utility Support Trailer (UST), which offers 270.7 cu. ft. of storage space and a 5kW genset. The shelter can also be transported on the HP-8 UST Trailer or using another kind of specially-designed container.

Despite its size, the J Series Shelter is easy to set up. The total deployment time for the J Shelter from when the shelter leaves the trailer bed to full set up is under 40 minutes and is achieved with

the assistance of a low-pressure air blower and bladder that comes with the J System.

Included Components:

- Titanite® Frame with Dual Pre-Attached Covers and Fabric Flooring
- J Transport and Storage Trailer with 6kW Genset or hydraulic container to fit 463L pallet (6kW Genset for blower optional with hydraulic container)
- Bladder and Blower with Duct
- Ladder and Sledge Hammer
- Two 1XBTJ Vestibule Entranceways
- Screen Windows and Vinyl Window Set
- Face Plate, T-Plate and Plenum
- Lights and Electrical Wiring Set
- Ground Stakes and Low and High Wind Lines
- End Wall Support Kit
- Field Repair Kit

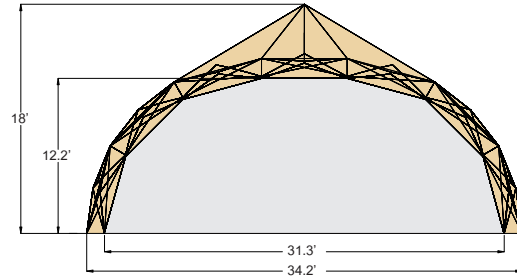



J SERIES

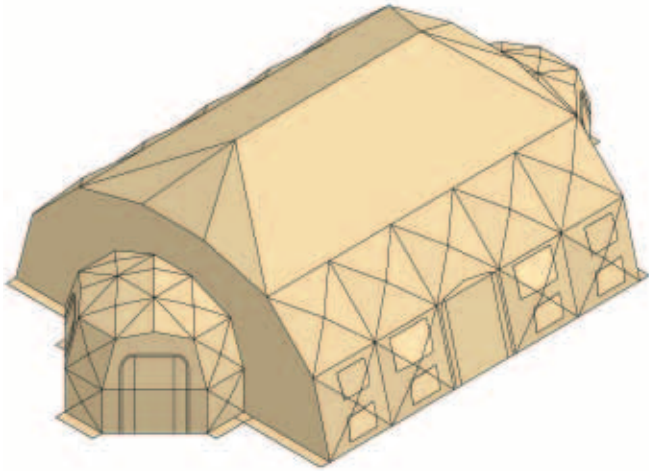

J Shelter System

(J Shelter on HP-J4)

Part Number: JA201440 (Green), JA201460 (Tan)

NSNs: 8340-01-487-6254 (Green) 8340-01-487-6271 (Tan)

The interior of the J Shelter System measures 51.4 feet long (15.7 meters) by 31.3 feet wide (9.5 meters) and provides a total of 1,250 square feet (116 square meters) of usable space. The interior height measures 13.8 feet (4.2 meters). It includes two 1XBTJ Vestibule Entranceways or End Caps.

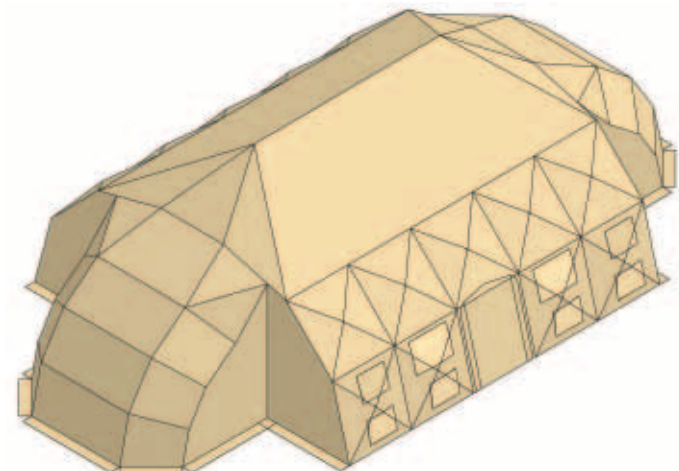

J Maintenance Shelter System

Part Number: JA209998 (Green), JA208887 (Tan)

NSNs: Pending

The interior of the J Maintenance Shelter System measures 58.9 feet long (17.9 meters) by 31.3 feet wide (9.5 meters) and provides a total of 1,323 square feet (122.9 square meters) of usable space. The interior height measures 13.8 feet (4.2 meters). *Maintenance Doors can also be sold separately.

J Shelter

Usable Area	sq. ft.	1,055
	sq. m.	98
Total Weight	lb.	1,600
	kg.	726
Packed Dimensions	in.	53 x 56 x 94
	cm.	135 x 142 x 239
Packed Volume	cu. ft.	300
	cu. m.	8.5

1XBTJ End Cap

Below numbers reflect one end cap. Two per shelter.

Usable Area	sq. ft.	97.7
	sq. m.	9
Total Weight	lb.	216
	kg.	97.8
Packed Dimensions	in.	52 x 33 x 22
	cm.	132 x 86 x 61
Packed Volume	cu. ft.	21.9
	cu. m.	0.6

J Shelter

Usable Area	sq. ft.	1,055
	sq. m.	98
Total Weight	lb.	1,600
	kg.	726
Packed Dimensions	in.	53 x 56 x 94
	cm.	135 x 142 x 239
Packed Volume	cu. ft.	300
	cu. m.	8.5

Maintenance Door

Below numbers reflect one door. Two per shelter.

Usable Area	sq. ft.	184
	sq. m.	17.1
Total Weight	lb.	292
	kg.	132.5
Width	ft.	15.5
	m.	4.7
Height	ft.	10
	m.	3

TRANSPORT THE J SHELTER

Depending on the available mode of transportation, the J Shelter is offered with either a container to fit a 453L Pallet or with a manually-tilting J Transport Trailer that allows the shelter to be pushed in place over its inflatable air bladder. The J Shelter can also be combined with an HP-8 UST Trailer to allow for a complete power, environmental control and mobility package that ensures optimum operations even in extreme weather conditions.

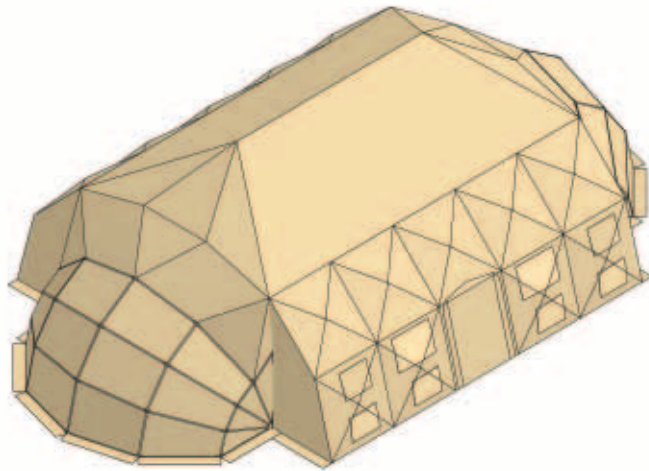

J UAV Maintenance Door

The J UAV Maintenance Door enables UAVs access to the J Maintenance Shelter for downloading data, repairs or for storage purposes. Easily affixed to the end caps of any J Series Shelter, the J UAV Maintenance Door is a clam shell retractable entry point that is the perfect complement to your J Shelter for all your larger UAV needs.

UAV Maintenance Door

Usable Area	sq. ft.	240
	sq. m.	22.3
Total Weight	lb.	295
	kg.	133.8
Width	ft.	20
	m.	6.1
Height	ft.	10
	m.	3



HP- 8



HP- J4



J Container

SPECIALTY SHELTERS



Arctic Tent

Part Numbers: 10 Man 00800G (Green); 00800T (Tan)
14 Man SH201-0907G (Green); 14 Man SH201-0907T (Tan)

Features:

- Designed to hold up to extreme conditions.
- Sets up in minutes with minimal personnel.

- Easily packed onto an Ahkio Sled for transport.
- Liner is made of permeable cotton sheeting that helps to insulate the tent.
- Removable floor is made from a heavy duty polyester material to provide a barrier against insects and vermin, abrasion and ground moisture.

- Two doors on opposite sides and four built-in ventilators provide air flow.
- Supports the Army's Family of Space Heaters (FOSH). May also be heated by a Yukon Stove.
- Built-in shelter skirts allow snow or weight to assist in the insulation and staking of the tent.

Five-year warranty for materials and workmanship.

Standard Components:

- XYTEX® Tent Material with Fire-Resistant Liner
- Stovepipe Opening, Vents & Foot Stops
- Tent Cover for Storage or Easy Transport
- Removable Floor
- Door Flaps with Zipper, Clips and Tie Tape
- Snow Cloth
- Telescopic Tent Pole
- Wind-lines & Eaves
- Stakes & Tent Slips

		10-Man	14-Man
Height (Peak)	ft.	8.5	9.6
	m.	2.6	2.9
Height (Eave)	ft.	3.0	3.0
	m.	0.9	0.9
Length (on each side)	ft.	8.8	10.2
	m.	2.7	3.1
Width (hexagonal floor diameter)	ft.	17.5	20.2
	m.	5.3	6.2
Usable Area	sq. ft.	198.9	260
	sq. m.	18.5	24.2
Weight (Tent and Liner)	lb.	68	122
	kg.	30.1	55.3
Weight (Pins and Pole)	lb.	8.0	8.0
	kg.	3.6	3.6
Packed Volume	cu. ft.	7.1	7.1
	cu. m.	0.2	0.2



EMI Shelter

Features:

- Designed to protect sensitive electronic equipment from the effects of Electromagnetic Interference (EMI)
- Interior cover, floor and doors are constructed from independently-tested RFI blocking material for a completely enclosed shield.
- Includes greater than -50dB attenuation of RFI over a frequency range of 150MHz to 3.0GHz.
- Robust grounding system protects personnel from Electrostatic Discharge (ESD) and Electrical System Fault.
- High-Altitude Electromagnetic Pulse (HEMP) protection significantly reduces

electromagnetic pulse effects to protect internal equipment.

- Lightning Protection System (LPS) mitigates the risks of direct lightning strike to the shelter.
- Operable in weather extremes from -50°F to 131°F.
- Each DRASH EMI Shelter can be integrated with a special Utility Support Transport (UST) Trailer to provide a seamless power and environmental control package.
- Interconnects with other shelters to increase overall footprint.
- Five-year warranty for materials and workmanship.
- DRASH EMI Shelters are available in C, S, XB and M Shelter variants, offering 109 to 748 square feet of usable space.



Satellite Antenna Shelter

Part Numbers: 0070TG (Green), 0070TT (Tan)
NSNs: 8340-01-467-9325 (Green), Pending (Tan)

Features:

- Designed to provide cover and concealment to satellite antennas up to eight feet in diameter while providing workspace for personnel. Deploys in minutes. No assembly required and no loose parts. No special tools are needed.
- Multiple “smiles” cut into the cover help reduce high wind loading.
- Operable in weather extremes from -50° to 131°F (-45.5°C to 55°C).
- Has met all military wind requirements as per testing at Aberdeen Proving Grounds.

Five-year warranty for materials and workmanship.

Standard Components:

- TITANITE® Frame with Pre-Attached Exterior XYTEX® Cover
- Ground Stake Loops and Wind Lines
- Interior Staking Loops and Stake Set
- Repair Kit
- Operators Manual/Instructions
- Push Poles
- Transport Bag

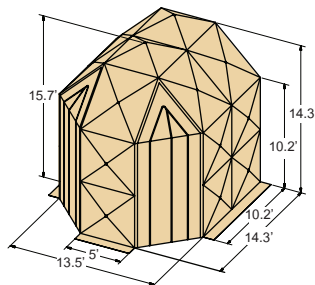

Usable Area	sq. ft.	75
	sq. m.	7
Total Weight	lb.	220
	kg.	99.7
Packed Dimensions	in.	66 x 29 x 21
	cm.	168 x 74 x 53
Packed Volume	cu. ft.	23.3
	cu. m.	0.7



Self Enclosed Annex Lobby (S.E.A.L.)

Part Numbers: 91100G (Green), 91100T (Tan)
NSNs: 8340-01-484-6713 (Green), 8340-01-484-6711 (Tan)

Features:

- DRASH shelter with a truncated opening on opposite ends.
- Creates a framed external entryway between XB and S Series Shelter doorways and a framed passageway between two XB or S Series Shelters.
- Hard door (see page 64) can be attached to form an entry control point.
- Maintains blackout and climate conditions.
- Can be deployed in minutes.

Five-year warranty for materials and workmanship.

Standard Components:

- TITANITE® Frame with Pre-Attached Exterior XYTEX® Cover
- Ground Stake Loops and Wind Lines
- Interior Staking Loops and Stake Set
- Repair Kit
- Operators Manual/Instructions
- Push Poles
- Transport Bag

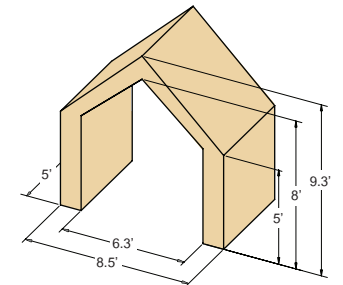

Usable Area	sq. ft.	31.2
	sq. m.	2.9
Total Weight	lb.	99
	kg.	44.9
Packed Dimensions	in.	66 x 21 x 21
	cm.	168 x 53 x 53
Packed Volume	cu. ft.	16.8
	cu. m.	0.5

SPECIALTY SHELTERS



Decontamination System

Perfect for Homeland Response Forces (HRF), Chemical Biological Rapid Response Teams (CBRRT), and all military forces with decontamination responsibilities, DRASH decontamination solutions are based on state-of-the-art shelter technology to ensure thorough NBC decontamination for the maximum number of patients or personnel while minimizing the amount of time needed for setup.

The durable, fully-operational, decontamination systems deploy in any terrain and can withstand extreme weather and temperature conditions. Our decontamination systems are based on the patented Deployable Rapid Assembly Shelter (DRASH), a free-standing, self-supporting structure that requires no power or air to erect. Our systems rapid deployment capabilities are specifically engineered to effectively decontaminate both male and female ambulatory, non-ambulatory patients and technical work crews in the event of a CBRNE (chemical, biological, radiological, and nuclear) incident.

Perfect for deploying in any situation with only minimal personnel, our system includes an open interior for rapid decontamination, curtains for patient modesty, a collapsible-wall berm for complete run-off containment, multiple showerheads and spray wands, and a self-heating, thermostatically-controlled multi-fuel water heater that provides up to 28 gallons per minute – all deployable in less than 6 minutes.

Other options include interoperable water heating systems, roller systems, patient tracking materials, lighting and environmental control systems. Larger systems include privacy curtains for separate undress, shower and redress areas. Fully operational system berms contain all water runoff, significantly reducing the chance of cross contamination. Additionally, each decontamination system can be equipped with a transport-style duffel bag, repair kit, push poles, wind lines and a steel pin stake set.



Mobile Hygiene System, 8 Stall Complete

Part Numbers: RDPK0371 (Green), 1010044 (Tan)

Features:

- Various shower and sink configurations available to meet customers' needs.
- Includes a durable, fire retardant, mold and mildew resistant, waterproof cover.
- Frame is manufactured from Titanite®, an aerospace composite material with superior structural properties.
- Shelter sets up in minutes without the use of special tools.
- Plumbing lines are integrated into the interior shelter frame, allowing for an easier and more rapid set up. They are supplied by 35-foot, heavy-duty, abrasion-resistant hoses that connect them to the water heater via Cam-lock fittings.
- Wash basins and six-foot long benches form the common wash area.
- Individual shower stalls include 2.5 gpm showerheads with quick-connect fittings and built-in shut offs.
- A rigid-wall containment berm features 8" high side walls and raised floors for optimum water runoff conditions.
- "Intellipump" automatically turns on with the presence of water and turns off when level is below ¼ inch.

Major Components:

- Shelter with integrated plumbing
- Water Heater and water hoses
- Water Supply Adapter Kit
- Sinks
- Benches
- Lights
- Bladders, fresh and waste water
- Containment Berm
- Elevated Grid Flooring

G2 Water Heating System*:

- 425,000 BTU/28 gpm self-heating, thermostatically-controlled system.
- 10-gallon onboard fuel tank with drain plug; multi-fuel use. Fuels include diesel, kerosene, home heating oil, JP4 or JP8.
- Thermostatically-controlled, built-in, anti-scald protection device; in-line GFI protection.
- 1/5 hp, 120V, 60 hz, single phase burner motor runs at 3,450 rpm.
- Solid state, no flame electrical system ignites on water flow.

* EU models available, please contact DHS International representatives for more information.

SPECIALTY SHELTERS



Patient Isolation System

Features:

- Provides 402-515 usable square feet of negatively or positively pressurized treatment space.
- Sets up in minutes with minimal personnel.
- Biologically secure staff anteroom allows medical personnel to don or doff gear before entering and after exiting pressurized patient treatment area.
- Zippered entry and exit doors and heat-sealed viewing windows provide complete containment while allowing personnel to view inside the shelter without entering.
- Anteroom wall can also be tied back to open up the shelter for other uses.
- Available with filtration/HVAC system or stand-alone filtration system.



Standard Components:

- TITANITE® Frame with Pre-Attached Exterior XYTEX® Cover
- Ground Stake Loops and Wind Lines
- Interior Staking Loops and Stake Set
- Repair Kit
- Operators Manual/Instructions
- Push Poles
- Transport Bag

State-of-the-Art Filtration Systems

Two filtration systems are available for use with the Outdoor Patient Isolation System: a stand-alone filtration system and a filtration/HVAC system.

Filtration/HVAC System:

- Airflow: 2220 cfm.
- Flexible, foil-coated, disposable air input/output ducts.
 - Female input connectors on unit port; male duct collars.
 - Male output connectors on unit port; female duct collars.
- Power ratings of 240 volt, 50 amp, 60 Hz.
- Heat and cooling outputs of 60,000 BTU.
- Two banks of two elements for low and high heating.
- Pressure Differential: 0.1" to 0.12" WC.
- Onboard adjustable dampers for positive and negative pressurizing.
- Remote thermostat allows for dual level heating and single level heating.
- HEPA filter and UV lamps.
- Automatic overheating shutdown.
- Auditory alarm and light indicator detect filter blockage and/or UV failure.
- Dimensions: 35.5"W x 69.25"L x 73"H.
- Weight: 862 lbs.

Stand-Alone Filtration System:

- Portable, all-weather design for use in the elements.
- Constructed from powder-coated aluminum alloy case.
- Airflow: 2,500 CFM.
- Power: Three phase, 230VAC 8A, 60 Hz.
- Three horsepower, variable control, belt drive industrial grade motor with 1 and 1/8" shaft.
- System maintains positive or negative pressure of 0.01 WG for isolation to meet CDC guidelines for infection control.
- CDC Capacity: 12 ACH in spaces of up to 12,500 CFM.
- Filtration: 99.99% @.3Microns.*
- Ozone Free Germicidal UV @253.7 nm.
- Automatic controls.
- Power, filter and pressure indicators.
- Heavy-duty, all-terrain casters allow for field applications.
- Dimensions: unit: 33"W x 41.1"L x 63"H, duct: 16".
- Weight: unit: 280 lbs., filters: 20 lbs. ea.

Optional Features:

- Ozone Generation for additional sterilization method of the air purification unit.
- Software package for data logging.
- Web browser capability for access of web.
- Remote notification of alarm status to PDA, Cell, Pager.

* Each filter is individually and independently certified with an efficiency test rating. 99.99% is the maximum efficiency level. Minimum efficiency is 99.97%.



Entry Control Point

Part Numbers: 1009460

The DRASH Entry Control Point combines the DRASH Self Enclosed Annex Lobby (SEAL) Shelter with a impact-resistant, hard door to offer users a secure, extended entryway in which personnel can control access into any DRASH facility.

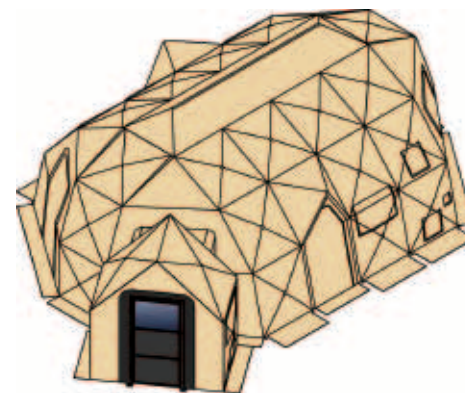

Features:

- Deploys in minutes to provide 31 square feet of usable space.
- Built to withstand harsh environmental conditions; door is constructed from impact-resistant fiberglass.
- Lightweight design allows for easy transport.
- Self-closing hinges shut door securely behind user.
- Built-in latch keeps door shut regardless of high winds.
- Door comes preattached to 3'6" x 4' x 2" sheet of BikeTrack™ flooring for easy opening and closing; can also be mounted to any similar hard flooring.
- Window includes a pre-attached blackout cover for light discipline.
- Door can be sold separately to attach to any C, XB, M or J Series end cap door within minutes.

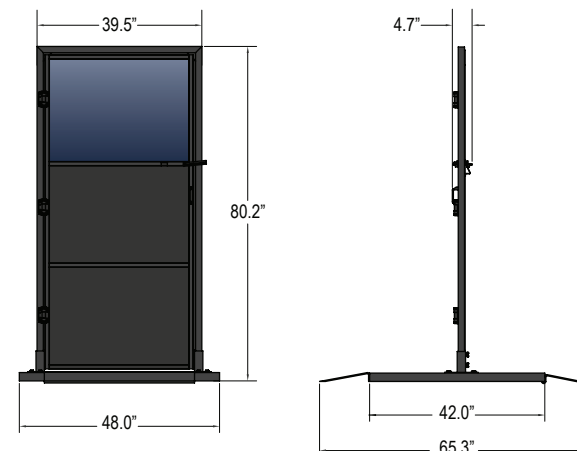

UST TRAILERS

The DRASH Utility Support Transport (UST) Trailer is an integrated support system designed to provide mobility, power, and/or environmental control to DRASH shelters. Operable in all terrain acceptable for military vehicles and easily towed behind military vehicles, DRASH UST Trailers conform to established “safe to transport” criteria by the Military Transport Management Command (MTMC) as suitable for “secondary and unimproved roads” and sealift transportability. Many trailers are also certified for air transport aboard select military aircraft.

UST Trailers come in two variants: analog or Intelligent Power Technology® (IPT) the newest variant available. DRASH gensets utilize IPT or a digital smart system that allows for networked power in the field for increased fuel efficiency (to learn more about IPT, see page 5).

Select UST Trailer models include genset outputs ranging from 5 to 60 kW. Additionally, many trailers feature 5-ton, 8-ton or 12-ton environmental control units (ECUs). Those models with ECUs include one or two supply ducts and one or two return air ducts per unit, which are de-

signed to attach to any soft-walled shelter at designated ports, providing a light-tight, weather-tight air seal.

Select models of DRASH UST Trailers also include a 5, 16, 20, 26, 45 or 63 gallon diesel fuel tank and the capability to take fuel from any external fuel source.

DRASH UST Trailers have been tested at the Aberdeen Test Center (ATC) in Maryland and the Nevada Automotive Testing Center (NATC) to meet all U.S. Military standards for trailers.

Trailer Model	NSNs		Part Numbers		Generator	EQU	Cargo
	Green	Tan	Green	Tan			
HP-2C/18	NSN PENDING	NSN PENDING	1006117	1006118	•		•
HP-2C/5E	NSN PENDING	NSN PENDING	1006177	1006176		•	•
HP-2C/8E	—	—	1006179	1006178		•	•
HP-2C/33	NSN PENDING	NSN PENDING	1008839	1008838	•		•
HP-2C/185	NSN PENDING	NSN PENDING	1006672	1006673	•	•	•
HP-2C/188	8340-01-459-4366	8340-01-459-1803	1011202	1011203	•	•	•
HP-2C/285	NSN PENDING	NSN PENDING	1007248	1007247	•	•	•
HP-2C/288	NSN PENDING	NSN PENDING	1011104	1011105	•	•	•
HP-2C/338	8340-01-513-9267	8340-01-514-0578	1011204	1011205	•	•	•
HP-4G/18	NSN PENDING	NSN PENDING	1005721	1005720	•		•
HP-4G/33	NSN PENDING	8340-01-504-2614	1005723	1005722	•		•
HP-4/188	8340-01-459-4352	NSN PENDING	1010077	1010076	•	•	•
HP-4/338	8340-01-541-0577	NSN PENDING	1009414	1009413	•	•	•
HP-4/3312	NSN PENDING	NSN PENDING	1010078	1010079	•	•	•
HP-6G/18	NSN PENDING	NSN PENDING	1009323	1009322	•		•
HP-6G/33	NSN PENDING	NSN PENDING	1009672	1009671	•		•
HP-6G/60	NSN PENDING	NSN PENDING	1011210	1008592	•		•
HP-6G/185	NSN PENDING	NSN PENDING	1011206	1011207	•	•	•
HP-6/335	NSN PENDING	NSN PENDING	1009674	1009673	•		•
HP-6/338	NSN PENDING	NSN PENDING	1009676	1009675	•		•
HP-J4	8340-01-533-1695	8340-01-533-1656	T2-80600G	T2-80600T			
HP-8	—	—	1007318	1007317	•	•	•
HMCT	8340-01-513-9687	8340-01-513-9692	T2-80721G	T2-80721T			





EU models are available. Please contact DHS International representatives for more information.

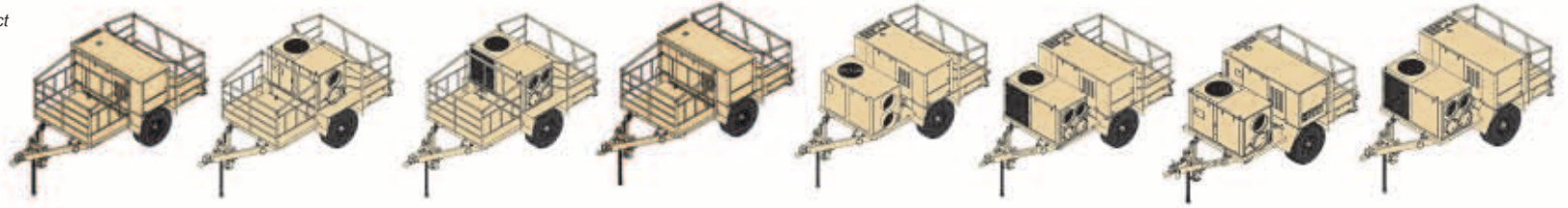

		HP-2C/18 IPT	HP-2C/5E	HP-2C/8E	HP-2C/33 IPT	HP-2C/185 IPT	HP-2C/188 IPT	HP-2C/285 IPT	HP-2C/288 IPT
FEATURES	Genset Output	kW	18	N/A	N/A	33	18	18	28
	Fuel Tank Capacity	Gal / l	16 / 60.6	5 / 18.9	5 / 18.9	26 / 98.4	16 / 60.6	16 / 60.6	20 / 75.7
	ECU Output	ton	N/A	5	8	N/A	5	8	5
	Cargo Volume	cu.f. / cu.m.	145 / 4.1	145 / 4.1	145 / 4.1	145 / 4.1	77 / 2.2	77 / 2.2	58 / 1.6
DIMENSIONS	Length	in. / m.	194 / 4.9	194 / 4.9	194 / 4.9	194 / 4.9	194 / 4.9	194 / 4.9	177 / 4.5
	Width	in. / m.	86 / 2.2	86 / 2.2	86 / 2.2	86 / 2.2	86 / 2.2	86 / 2.2	86 / 2.2
	Height	in. / m.	78 / 2.0	81 / 2.1	81 / 2.1	78 / 2.0	78 / 2.0	78 / 2.0	78 / 2.0
WEIGHTS	Tare	lbs. / kg.	2,862 / 1,298	2,173 / 986	2,382 / 1,081	3,362 / 1,525	3,340 / 1,515	3,549 / 1,610	3,670 / 1,668
	Gross	lbs. / kg.	4,200 / 1,905	4,200 / 1,905	4,200 / 1,905	4,200 / 1,905	4,200 / 1,905	4,200 / 1,905	4,200 / 1,905
	Tongue	lbs. / kg.	260 / 118	240 / 109	250 / 113	280 / 127	243 / 110	379 / 172	200/91

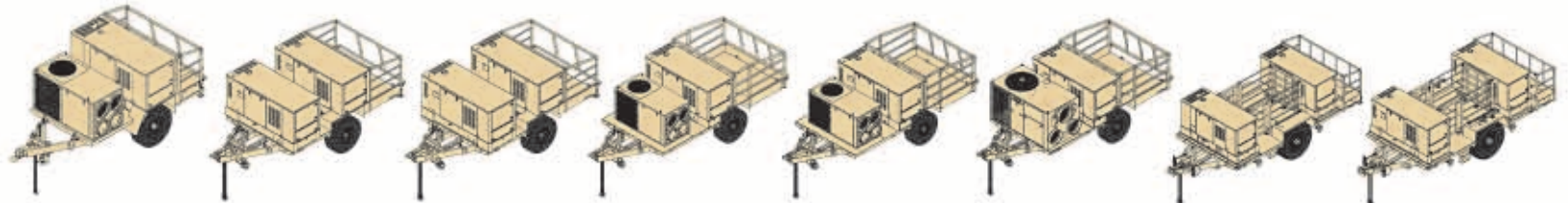

		HP-2C/338 IPT	HP-4G/18 IPT	HP-4G/33 IPT	HP-4/188 IPT	HP-4/338 IPT	HP-4/3312 IPT	HP-6G/18 IPT	HP-6G/33 IPT
FEATURES	Genset Output	kW	33	18 (x2)	33 (x2)	18	33	33	18 (x2)
	Fuel Tank Capacity	Gal / l	26 / 98.4	16 / 60.6 (x2)	26 / 98.4 (x2)	16 / 60.6	26 / 98.4	26 / 98.4	16 / 60.6 (X2)
	ECU Output	ton	8	N/A	N/A	8	8	12	N/A
	Cargo Volume	cu.f. / cu.m.	58 / 1.6	79 / 2.2	79 / 2.2	140 / 4.0	140 / 4.0	140 / 4.0	145 / 4.1
DIMENSIONS	Length	in. / m.	177 / 4.5	204 / 5.2	204 / 5.2	228 / 5.8	228 / 5.8	228 / 5.8	253.5 / 6.4
	Width	in. / m.	86 / 2.2	86 / 2.2	86 / 2.2	86 / 2.2	86 / 2.2	86 / 2.2	96 / 2.4
	Height	in. / m.	78 / 2.0	78 / 2.0	78 / 2.0	78 / 2.0	78 / 2.0	78 / 2.0	87 / 2.2
WEIGHTS	Tare	lbs. / kg.	Pending	4,719 / 2,141	Pending	Pending	4,737 / 2,149	5,292 / 2,400	8,235 / 3,735
	Gross	lbs. / kg.	4,200 / 1,905	6,500 / 2,948	6,500 / 2,948	6,500 / 2,948	6,500 / 2,948	12,000 / 5,443	12,000
	Tongue	lbs. / kg.	344 / 156	575 / 261	Pending	Pending	302 / 137	792 / 359	565 / 256

EU models are available. Please contact DHS International representatives for more information.

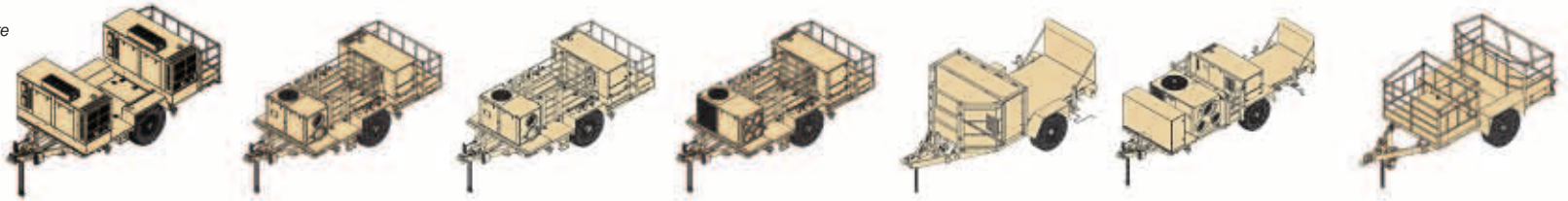

		HP-6G/60 IPT	HP-6G/185 IPT	HP-6/335 IPT	HP-6/338 IPT	HP-J4	HP-8 IPT	HMCT	
FEATURES	Genset Output	kW	60 (x2)	18	33	33	5	33	N/A
	Fuel Tank Capacity	Gal / l	63 / 239 (x2)	16 / 60.6	26 / 98.4	26 / 98.4	N/A	45 / 170.3	N/A
	ECU Output	ton	N/A	5	5	8	N/A	12	N/A
	Cargo Volume	cu.f. / cu.m.	53.1 / 1.5*	145 / 4.1	145 / 4.1	145 / 4.1	270 / 7.7	319 / 9	145 / 4.1
DIMENSIONS	Length	in. / m.	254 / 6.5	253.5 / 6.4	253.5 / 6.4	253.5 / 6.4	209 / 5.3	312.5 / 7.9	194 / 4.9
	Width	in. / m.	96 / 2.4	96 / 2.4	96 / 2.4	96 / 2.4	91.5 / 2.3	96.8 / 2.5	86 / 2.2
	Height	in. / m.	91 / 2.3	87 / 2.2	87 / 2.2	87 / 2.2	80 / 2.0	91 / 2.3	78 / 2.0
WEIGHTS	Tare	lbs. / kg.	Pending	Pending	Pending	Pending	2,588 / 1,174	8,071 / 3,661	1,568 / 711
	Gross	lbs. / kg.	Pending	12,000 / 5,443	12,000 / 5,443	12,000 / 5,443	6,000 / 2,722	12,000 / 5,443	4,200 / 1,905
	Tongue	lbs. / kg.	Pending	Pending	Pending	Pending	758 / 344	1,080 / 490	420 / 191

* In addition to a rear cargo area that provides 53.1 cu. ft. of usable space, the HP-6G/60 IPT also includes a middle storage area that offers 18.5 sq. ft. of usable space.

SKID MOUNTED ECU

NSNs: Pending [5 Ton], 8340-01-513-9655 (Green); 8340-01-514-0798 (Tan) [8 Ton]; Pending [12 Ton]
Skid includes 5 gallon fuel tank for Webasto Heater.

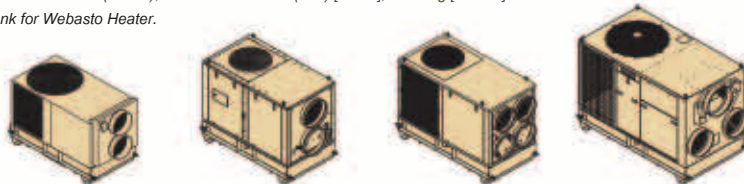

	3.5 Ton*	5 Ton**	8 Ton	12 Ton
Ducts (supply/return)	2	2	4	3 or 4
Cooling Capacity (BTU/hr)	42,000	60,000	96,000	144,000
Heating Capacity (BTU/hr)	42,000	61,000	92,420	165,000
Length [in. / m.]	48 / 1.2	66 / 1.7	71 / 1.8	83 / 2.1
Width [in. / m.]	35 / 0.9	34 / 0.9	34 / 0.9	45 / 1.1
Height [in. / m.]	45 / 1.1	52 / 1.3	52 / 1.3	61 / 1.5
Weight [lbs. / kg.]	398 / 180.6	750 / 340.2	950 / 430.9	1,490 / 675.9

* The DRASH 3.5 Ton ECU is a commercial environmental control unit and does not come standard on any DRASH UST Trailer.

** A commercial version of the DRASH 5 Ton ECU is also available.

SKID MOUNTED GENSET

POWER OUTPUT: 208V / 3 PHASE / 60 HZ

NSNs: Pending

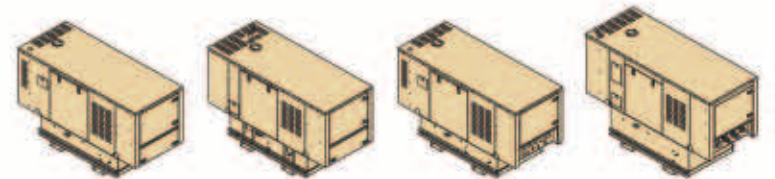

	18 kW IPT	28 kW IPT	33 kW Std. IPT	33 kW Large IPT
Fuel Capacity (Gal. / L.)	16 / 60.6	20 / 75.7	26 / 98.4	45 / 170.3
Control	Analog/Digital	Digital	Analog/Digital	Analog/Digital
Length [in. / m.]	85 / 2.2	85 / 2.2	85 / 2.2	90 / 2.3
Width [in. / m.]	35 / 0.9	35 / 0.9	35 / 0.9	35 / 0.9
Height [in. / m.]	57 / 1.4	57 / 1.4	57 / 1.4	62 / 1.6
Weight [lbs. / kg.]	1,475 / 669	1,775 / 805.1	1,925 / 873.2	1,975 / 895.8

A Turf Cart is available to easily transport ECUs and gensets. See page 90.

DC2E

First introduced in 2005, DRASH Deployable Command and Control Equipment (DC2E) was developed to solve the information management problems facing today's commander. Comprised of projector systems and audio visual switching systems, DC2E provides lightweight, portable communications technology by fusing multiple feeds of information onto a single display or more if needed.

Numerous Display Systems

Available in various sizes and projection configurations, DC2E screen displays have been designed to accommodate any permanent or temporary facility.

Reliable Audio-Visual Systems

DC2E audio-visual systems are also available in various configurations. All DC2E audio-visual systems feature diskless components for increased reliability, the ability to support multiple displays and display types and molded, weather-resistant transport cases for easy transport.

Convenient Accessories

Accessories, including a microphone system, clock and tables featuring storage space for cables and wires, are available.

Readily Available

DC2E products are available for purchase through DSCP or GSA using contract number GS-03F-0181V.





DC2E MEDIUM SCREEN DISPLAY, SXGA+

Part Number: BP300A019



Designed for 24/7 operation, the DC2E Medium Screen Display, SXGA+ is built for today's commander. The system features a DLP projector that accepts and displays images with a resolution of up to 1920 x 1200. Despite its numerous capabilities, the Medium Screen Display is compactly stored in two separate wheeled cases for easy transport.

Multiple screen systems can also connect together to form a dual screen (1008844) or triple screen (1008843) system.

Features:

- Native 1400 x 1050 (SXGA+) resolution. System accepts and displays images with a resolution of up to 1920 x 1200.
- Wide range of signal compatibility.
- Viewing area measures 59" x 44" x 73" diagonal.
- Designed for 24/7 operation. To ensure continuous operation, a maintenance kit is available for the projector that replaces all moving internal components within 8,000 hours of system operation.
- 2000/3000-hour lamp life, 300-watt lamp, 2600 ANSI lumens weighs only 9 lbs. (4 kg.) and has a low noise level of only 28 dB(A).
- Power 100-240 VAC, 4A, 50/60 Hz.
- Lightweight 1" square aluminum frame system with locking hinge points for fast set up and take down.
- Includes long life mechanical elements, such as magnesium and ceramics, as well as over specified fans and color wheel engine.
- Fully sealed optical architecture ensures faultless operation in harsh environments.
- Cantilevered projector mounting arm preserves valuable floor space.
- Multiple projection screens can be connected together to form a single large screen.

Optional Components:

An optional cooling kit helps regulate projector temperature and prevent dust and debris from collecting on the projector in high temperature conditions (patent pending).

Packaging:

Screen and projector may be stored in two cases with wheels for easy transport.

Packaging:

Screen and projector may be stored in two cases with wheels for easy transport.

Packed Projector Case Case 1:	Dimensions:	in.	24.5 W x 19.5 D x 15 H
		cm.	62 W x 50 D x 38 H
	Weight:	lb.	41
		kg.	18.6
Packed Screen and Frame Case Case 2:	Dimensions:	in.	50 W x 17.5 D x 13 H
		cm.	127 W x 44.5 D x 33 H
	Weight:	lb.	74
		kg.	33.6

DC2E MEDIUM SCREEN DISPLAY, XGA

Part Number: 1009852



The entry-level DC2E Medium Screen Display, XGA features a DLP projector that accepts and displays images with a resolution of up to 1280 x 1024. Despite its numerous capabilities, the Medium Screen Display is compactly stored in two separate wheeled cases for easy transport.

Multiple screen systems can also connect together to form a dual screen (1009853) or triple screen (1009861) system.

Features:

- Native 1024 x 768 (XGA) resolution. System accepts and displays images with a resolution of up to 1280 x 1024.
- Wide range of signal compatibility.
- Viewing area measures 59" x 44" x 73" diagonal.
- 4000/6000-hour lamp life, 220-watt lamp, 2600 ANSI lumens weighs only 5.5 lbs. (2.5 kg.) and has a low noise level of only 32 dB(A).
- Power 100-240 VAC, 2.5A, 50/60Hz.
- Lightweight 1" square aluminum frame system with locking hinge points for fast set up and take down.
- Cantilevered projector mounting arm preserves valuable floor space.
- Multiple projection screens can be connected together to form a single large screen.
- Spare lamp included.

Packaging:

Screen and projector may be stored in two cases with wheels for easy transport.

Packed Projector Case Case 1:	Dimensions:	in.	24.5 W x 19.5 D x 15 H
		cm.	62 W x 50 D x 38 H
	Weight:	lb.	35
		kg.	15.9
Packed Screen and Frame Case Case 2:	Dimensions:	in.	50 W x 17.5 D x 13 H
		cm.	127 W x 44.5 D x 33 H
	Weight:	lb.	74
		kg.	33.6

DC2E LARGE SCREEN DISPLAY



Designed to fit into a DRASH J Series Shelter, the DC2E Large Screen Display features three DLP projectors that project three separate large, high resolution images. Its unique configuration allows it to be set up nearly five feet above the floor allowing for ease of viewing from the back of the TOC. Regardless of its size, the Large Screen Display system packs down tightly into three lightweight cases and does not require any tools for installation.

The DC2E Large Screen Display is available as a Front Projection Screen Display system, offering three 90" diagonal viewing areas, or as a Rear Projection Screen Display system, offering three 76.7" diagonal viewing areas.

Features:

- Native 1400 x 1050 (SXGA+) resolution. System accepts and displays images with a resolution of 640 x 480 to 1920 x 1200.
- Front Projection Screen measures 5.5' x 19' to allow for three separate 54" x 72" x 90" diagonal viewing areas; Rear Projection Screen measures 3.9' x 15.2' to allow for three separate 47" x 60.6" x 76.7" diagonal viewing areas.
- Three DLP projectors are designed for 24/7 operation. To ensure continuous operation, a maintenance kit is available for the projector that replaces all moving internal components within 8,000 hours of system operation.
- 2000/3000 hour lamp life, 300-watt lamp, 2600 ANSI lumens weighs only 9 lbs. (4 kg.) and has

- a low noise level of 28 dB(A).
- Power 100-240 VAC, 12A, 50/60 Hz.
- Lightweight 1" square tube aluminum frame system with locking hinge points allows for fast set up and take down.
- Includes long life mechanical elements, such as magnesium and ceramics, as well as over specified fans and color wheel engine.
- Fully sealed optical architecture ensures faultless operation in harsh environments.
- Lightweight 2" tube frame supports all three projectors. Rugged, black, rubberized coating allows for increased durability. Slip fit joint system features quick securing clips.
- Three projector mounts with wide adjustability included for set up on uneven terrain.
- One 50Ft. and two 25Ft. HD15 VGA video cables included. One 30Ft. NEMA 5-15 extension cable and one 6 outlet power strip included.

FRONT PROJECTION SCREEN DISPLAY

Part Number: 1002543

Packed Projector Case Case 1:	Dimensions:	in.	80.8 W x 22.5 D x 18 H
		cm.	205.1 W x 57.2 D x 45.7 H
	Weight:	lb.	150
		kg.	68.2
Packed Screen and Frame Case Case 2:	Dimensions:	in.	80.8 W x 22.5 D x 18 H
		cm.	205.1 W x 57.2 D x 45.7 H
	Weight:	lb.	190
		kg.	86.4
Packed Screen and Frame Case Case 3:	Dimensions:	in.	80.8 W x 22.5 D x 18 H
		cm.	205.1 W x 57.2 D x 45.7 H
	Weight:	lb.	150
		kg.	68.2

REAR PROJECTION SCREEN DISPLAY

Part Number: 1004180

Packed Projector Case Case 1:	Dimensions:	in.	80.8 W x 22.5 D x 18 H
		cm.	205.1 W x 57.2 D x 45.7 H
	Weight:	lb.	150
		kg.	68.2
Packed Screen and Frame Case Case 2:	Dimensions:	in.	80.8 W x 22.5 D x 18 H
		cm.	205.1 W x 57.2 D x 45.7 H
	Weight:	lb.	163
		kg.	73.9
Packed Screen and Frame Case Case 3:	Dimensions:	in.	80.8 W x 22.5 D x 18 H
		cm.	205.1 W x 57.2 D x 45.7 H
	Weight:	lb.	160
		kg.	72.6

DC2E LARGE FRONT/REAR SCREEN DISPLAY

Part Number: 1007655



Designed to fit into a DRASH J Series Shelter, the DC2E Large Front/Rear Projection Screen Display system features three DLP projectors that project three separate large, high resolution viewing areas. Its unique design allows it to be set up in a front or rear projection configuration. The entire system including truss, screen, projectors and cables packs down tightly into four cases. All cases have large handles on all sides, a purge valve and wheels on one end to increase transportability.

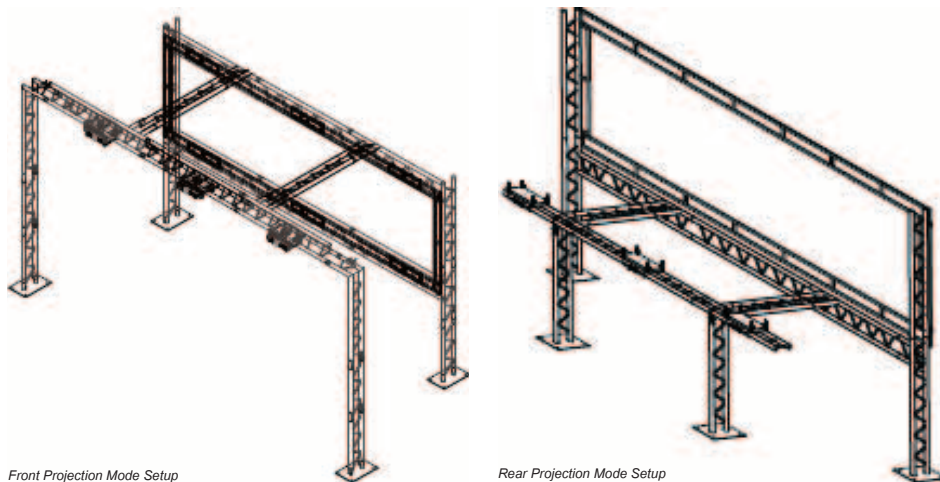

Front Projection Mode Setup

Rear Projection Mode Setup

Features:

- Native 1400 x 1050 (SXGA+) resolution. Accepts resolutions from 640 x 480 through 1920 x 1200.
- Front projection configuration features three independent viewing areas of 54" x 72" x 90" diagonal.
- Rear projection configuration features three independent viewing areas of 45" x 60" x 75" diagonal.
- Images are greater than 48" above the floor allowing for ease of viewing from the back of the TOC.
- Three DLP projectors are designed for 24/7 operation. Includes long life mechanical elements, such as magnesium and ceramics, as well as over specified fans and a color wheel engine.
- Fully sealed optical architecture ensures faultless operation in harsh environments. Depot level, 8000 hour maintenance kit replaces all moving parts.
- 2000/3000 hour lamp life, 300-watt lamp and 2600 ANSI lumens. Each projector weighs only 9 lbs and has a low noise level of only 28 dB(A).
- Power 100-240 VAC, 12A, 50/60 Hz.
- Lightweight 2" tube frame structure with rugged black coating supports projectors and screen. Includes adjustable feet for uneven terrain.
- Each of the three projector mounts allow for easy adjustments and stow attached to the projector.
- Setup time for either front or rear configuration is less than 30 minutes using four people. No tools required.

Packed Projector Case Case 1:	Dimensions:	in.	80.8 W x 22.5 D x 18 H
		cm.	205.1 W x 57.2 D x 45.7 H
	Weight:	lb.	165
		kg.	74.8
Packed Screen and Frame Case Case 2:	Dimensions:	in.	80.8 W x 22.5 D x 18 H
		cm.	205.1 W x 57.2 D x 45.7 H
	Weight:	lb.	175
		kg.	79.4
Packed Screen and Frame Case Case 3:	Dimensions:	in.	80.8 W x 22.5 D x 18 H
		cm.	205.1 W x 57.2 D x 45.7 H
	Weight:	lb.	192
		kg.	87.1
Packed Screen and Frame Case Case 4:	Dimensions:	in.	80.8 W x 22.5 D x 18 H
		cm.	205.1 W x 57.2 D x 45.7 H
	Weight:	lb.	167
		kg.	75.7

TUFF-TABLES™

TACTICAL UTILITY FIELD FURNITURE



Features:

- Constructed from lightweight, rustproof, powder coated aluminum, TUFF-TABLES™ are durable and made for field use.
- Includes convenient storage space on the underside to hold cables, wires, mobile phone chargers, etc.*
- Folds for easy transport/storage.
- Supports 2,000 lbs (907 kg) of distributed weight.
- Cable management adapters available as an accessory.*
- Height from top of table measures 29.75"; leg clearance height measures 28".

* Features apply only to BP300A005

Small: BP300A005	Dimensions:	in.	24 x 72
		cm.	61 x 183
	Weight:	lb.	32
		kg.	17
Large: BP300A000-00001	Dimensions:	in.	30 x 72
		cm.	76 x 183
	Weight:	lb.	38
		kg.	14.5

IDD5™

INTELLIGENT DATA DISTRIBUTION SYSTEM

Part Number: 1009700



The newest product to join the DRASH line of Deployable Command and Control Equipment (DC2E), the Intelligent Data Distribution System (IDD5™) offers users a durable, cost-effective method of distributing power and network connectivity throughout a temporary or fixed facility.

Able to connect to any table measuring one to two inches in thickness, the DRASH IDD5 allows personnel to store and protect cables while sharing power and network connectivity with up to six workstations. As many as three boxes can be daisy-chained together for extended power and network distribution. Made to withstand the harshest of field conditions, the IDD5 is rapidly deployable and can easily be stored and transported from one location to the next.

Features Include:

- Supports a wide range of communication technologies, including VoIP, video streaming and IP video conferencing
- Reduces the amount of cabling run across a facility to each workstation/operator position
- Clamp design allows box to attach to a wide range of field equipment
- Lightweight and stackable for easy mobility

I/O Panel:

- 2 separate 1GB networks, managed switches, 6 operator ports and network activity window
- 15 AMP resettable circuit breaker, power indicator L.E.D.
- NEMA 5-15 straight blade AC input/outputs
- 1 Duplex GFCI Outlet with trip indicator, 3 Duplex Outlets (GFCI Protected)
- Labels above and below each port for operation in either orientation
- Separate network highlighted by red background
- Stowed Dimensions (in bag): 49"L x 15"H x 10"D
- Stowed Weight: 36 lbs.

CLAMPS
• Accommodates table thicknesses of 1" – 2"

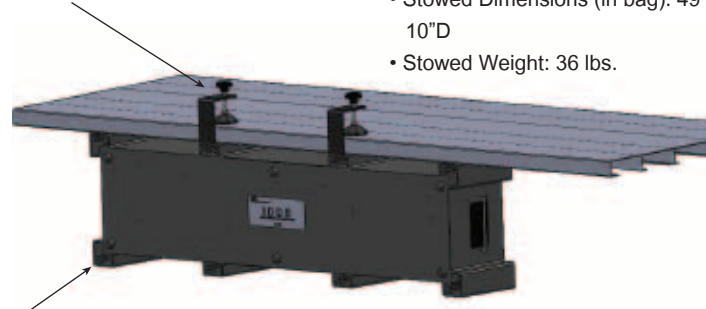

LUGS

- Multiple clamp location options
- Stand off from table for cable routing
- Stand off from surface moisture
- Ability to hang from other surfaces
- Protects latches from damage

MICROPHONE SYSTEM

Part Number: 1003688



Features:

- Includes Nine Delegate Stations, One Chairman Station and One Control Unit.
- Participants may easily follow and take part in a discussion through a table top station loudspeaker and a station microphone.
- The Chairman's Station allows the operator to take over the conference session with a push of a button.
- Control unit can handle up to 25 stations per line equaling a total of 50 stations.

Packaging:

The Microphone System with supplied extension cables stow in two cases. Both cases have integrated wheels for easy transport.

Case 1:	Dimensions:	in.	22 W x 31.3 D x 9.3 H
		cm.	55.9 W x 79.5 D x 23.6 H
	Weight:	lb.	36
		kg.	16.3
Case 2:	Dimensions:	in.	22 W x 31.3 D x 9.3 H
		cm.	55.9 W x 79.5 D x 23.6 H
	Weight:	lb.	28.5
		kg.	12.9

CLOCK SYSTEMS



Features:

- Available in either 3 or 4 panel display with vinyl* or digital lettering
- Vinyl lettering adheres to panel while digital lettering comes with software CD for all time zones worldwide
- Clock numerals are 4" in height and zone lettering are 1.2" in height enabling visibility up to 125 ft.
- Powered by 120VAC with current draw less than 35 watts
- Lithium battery back-up good for 10 years

Packaging:

The Clock System comes in a durable stow case with integrated wheels and handles for easy portability. Each case also includes power supply and power cable. Dimensions for stow case: 72.41"W x 6.61" H x 15.16"D

Note:

* Customer needs to specify what time zones they want.

System Name	Weight with Case
Vinyl 3 Time Zone Clock 1010608	49 lbs. / 22.2 kg.
Digital 3 Time Zone Clock 1010595	50 lbs. / 22.7 kg.
Vinyl 4 Time Zone Clock 1010594	54 lbs. / 24.5 kg.
Digital 4 Time Zone Clock 1010596	69 lbs. / 31.3 kg.

IPT REMOTE MONITOR

Part Number: 1011592



Features:

- The IPT (Intelligent Power Technology®) Remote Monitor allows an operator to remotely monitor up to 10 IPT Gensets simultaneously.
- It uses the same connection methods as the IPT Gensets making connections to the communications bus as simple as adding an additional genset.
- An RJ45 port is used to connect the IPT Remote Monitor to the local network or directly to a computer. A local user can simply enter the IP address of the IPT Remote Monitor and setup the generator(s) they would like to monitor.
- The operator can view the generator's engine information such as fuel level, water temperature and oil pressure. The operator can also view the generators power information such as overall generator voltage, frequency, total load and load per phase.

Power Requirements:

- 120VAC @60Hz
- Current Draw less than .15 Amps

Packed Case:

- 19" W x 15" D x 7" H
- 15.5 lbs.

DC2E AUDIO-VISUAL SYSTEMS

DC2E Audio-Visual Systems come in four different configurations: Mini, Small, Medium and Large (see next few pages). The following features are available for all configurations:

- Diskless components for increased reliability. Systems do not require additional software.
- Supports multiple displays and display types.
- POTS Line connects to standard analog phone line for audio conferencing.
- CTL LAN connects to LAN for WEB-based control of the AV System.
- Display processor combines 4 or 8 real-time video and computer inputs in Windows onto one display. Windows can be scaled up to full screen. Capable of accepting and displaying images with a resolution of up to 1600 x 1200.
- Includes molded, weather-resistant transport cases for the control system and accessories.



Notes:

* CV will auto-detect composite video (PAL / NTSC)

** CV will auto-detect HD / SD-SDI / composite video (PAL / NTSC)

DC2E A/V SYSTEM COMPARISON MATRIX																	
System Name	Video Inputs			Video Outputs		Multi - Window		Audio Inputs		Audio Outputs		Touch - Panel		Web Control	Acc. Case	Tele - Conf	Powered Speaker
	HD15 (RGB)	CAT5 (RGB)	CV	HD15	CAT5	4 Win	8 Win	Mic Level	Line Level	Line Level	With Video	W/O Video	Yes/No	QTY	Yes/No	QTY	
Large A/V System 120-240VAC 1005865	1	20	4*	3	12	4	0	4	4	4	1	0	Yes	2	Yes	2	
Medium A/V System 120-240VAC 1005216	1	12	4*	3	4	3	0	4	4	4	1	0	Yes	1	Yes	2	
Small A/V System 120-240VAC 1005218	1	8	2*	3	4	2	0	3	4	4	1	0	Yes	1	Yes	2	
Mini A/V System 120-240VAC 1005124	4	0	4**	1	0	0	1	2	2	2	0	1	Yes	1	Yes	1	

MINI AUDIO-VISUAL SYSTEM

Part Number: 1005124

Features:

- Interface via touch panel or secure Internet connection.
- Video In: Four HD15 Computer Inputs that accept up to 1920 x 1200 resolution. Four BNC Inputs automatically detect HD/SD-SDI & Composite (PAL/NTSC) for DVD/SAT TV and/ or Camera/UAV video.
- Audio In: Two Mic Level XLR Inputs and two Line Level XLR Inputs for DVD/SAT TV audio.

- Video Out: One HD15 output supporting multiple user selectable output resolutions.
- Audio Out: Two Line Level XLR outputs, one dedicated to speaker.
- Includes one AC-powered speaker with integrated 20 Watt amplifier for audio distribution.

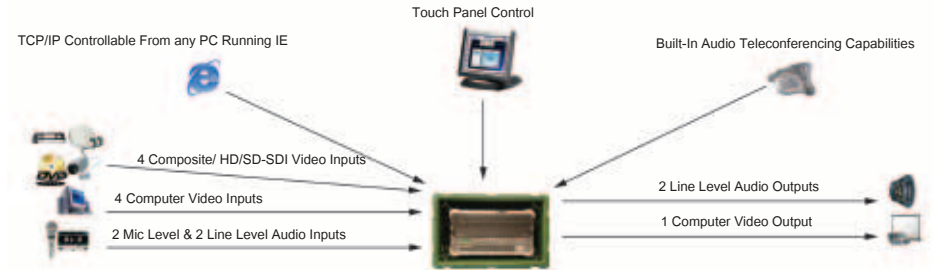

Packaging:

Mini AV Case

Molded, weather resistant, OD green case contains Control Processor, an Eight Window Video Processor and Audio Mixer.

Accessory Transport Case

Includes cables, touch panel and speaker.

Mini AV Case:	Outer Dimensions:	in.	40.4 L x 27 W x 16.6 H
		cm.	103 L x 69 W x 42 H
Accessory Transport Case:	Packed Weight:	lb.	115
		kg.	52
Accessory Transport Case:	Outer Dimensions:	in.	24 L x 20.5 W x 15 H
		cm.	61 L x 52 W x 38 H
Accessory Transport Case:	Packed Weight:	lb.	54
		kg.	25

SMALL AUDIO-VISUAL SYSTEM

Part Number: 1005218

Features:

- Control Interface via touch panel or secure Internet connection. Touch panels may also be used to view/cue video to be displayed on projection screens.
- Long Distance Video Distribution System: Uses RGBHV over CAT5 technology for long distance video distribution with minimal signal degradation.
- Video In: One HD15 and eight CAT5 Computer Inputs that accept up to 1600 x 1200 resolution. Two BNC Composite (PAL/NTSC) Inputs for DVD/SAT TV or Camera/UAV video.
- Audio In: Three Mic Level XLR Inputs and four Line Level XLR Inputs for DVD/SAT TV audio.
- Video Out: Three HD15 and four CAT5 Computer Outputs.

- Audio Out: Four Line Level XLR outputs; one dedicated to speaker.
- Includes two AC-powered speakers with integrated 20 Watt amplifier that can be daisy chained together for audio distribution.

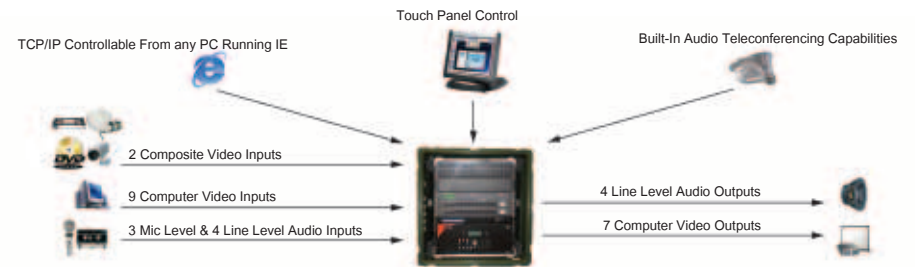

Packaging:

Small AV Case

Molded, weather resistant OD green case contains Control Processor, two Four Window Video Processors, a Quad Channel Video Scaler, an Audio Mixer and 12 x 12 RGBHV Matrix Switcher.

Accessory Transport Case:

Includes cables, touch panel, speakers and CAT5 TX/RX units.

Small AV Case:	Outer Dimensions:	in.	40 L x 27 W x 27.9 H
		cm.	101 L x 69 W x 71 H
Accessory Transport Case:	Packed Weight:	lb.	211
		kg.	96
Accessory Transport Case:	Outer Dimensions:	in.	30 L x 21.5 W x 30 H
		cm.	76 L x 55 W x 76 H
Accessory Transport Case:	Packed Weight:	lb.	138
		kg.	63

MEDIUM AUDIO-VISUAL SYSTEM

Part Number: 1005216

Features:

- Control Interface via touch panel or secure Internet connection. Touch panels may also be used to view/cue video to be displayed on projection screens.
- Long Distance Video Distribution: Uses RGBHV over CAT5 technology for long distance video distribution with minimal signal degradation.
- Video In: One HD15 and 12 CAT5 Computer Inputs that accept up to 1600 x 1200 resolution. Four BNC Composite (PAL/NTSC) Inputs for DVD/SAT TV and Camera/UAV video.
- Audio In: Four Mic Level XLR Inputs and four Line Level XLR Inputs for DVD/SAT TV audio.
- Video Out: Three HD15 and four CAT5 Computer Outputs.

- Audio Out: Four Line Level XLR outputs, one dedicated to speaker.
- Includes two AC-powered speakers with integrated 20 Watt amplifier that can be daisy chained together for audio distribution.

Medium AV Case:	Outer Dimensions:	in.	40.4 L x 27 W x 33 H
		cm.	103 L x 69 W x 84 H
	Packed Weight:	lb.	220
		kg.	99.8
Accessory Transport Case:	Outer Dimensions:	in.	30 L x 21.5 W x 30 H
		cm.	76 L x 55 W x 76 H
	Packed Weight:	lb.	151
		kg.	68

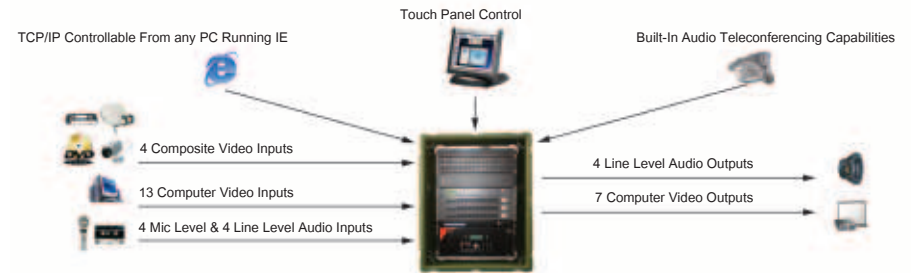

Packaging:

Medium AV Case

Molded, weather resistant OD green case contains Control Processor, three Four Window Video Processors, a Quad Channel Video Scaler, an Audio Mixer and a 20 x 20 RGBHV Matrix Switcher.

Accessory Transport Case

Includes cables, touch panel, speakers and CAT5 TX/RX units.

LARGE AUDIO-VISUAL SYSTEM

Part Number: 1005865

Features:

- Interface via touch panel or secure Internet connection. Touch panels may also be used to view/cue video to be displayed on projection screens.
- Long Distance Video Distribution: System uses RGBHV over CAT5 technology for long distance video distribution with minimal signal degradation.
- Video In: One HD15 and 20 CAT5 Computer Inputs that accept up to 1600 x 1200 resolution. Four BNC Composite (PAL/NTSC) Inputs for DVD/SAT TV or Camera/UAV.
- Audio In: Four Mic Level XLR Inputs and four Line Level XLR Inputs for DVD/SAT TV audio.
- Video Out: Three HD15 and twelve CAT5 Computer Outputs.
- Audio Out: Four Line Level XLR outputs, one dedicated to speaker.

- Includes two AC-powered speakers with integrated 20 Watt amplifier that can be daisy chained together for audio distribution.

Large AV Case:	Outer Dimensions:	in.	40.4 L x 27 W x 33 H
		cm.	103 L x 69 W x 84 H
	Packed Weight:	lb.	228.6
		kg.	103.7
Accessory Transport Case:	Outer Dimensions:	in.	30 L x 21.5 W x 30 H
		cm.	76 L x 55 W x 76 H
	Packed Weight:	lb.	173.8
		kg.	78.8
Accessory Transport Case 2:	Dimensions:	in.	30 L x 21.5 W x 30 H
		cm.	76 L x 55 W x 76 H
	Weight:	lb.	147.6
		kg.	67

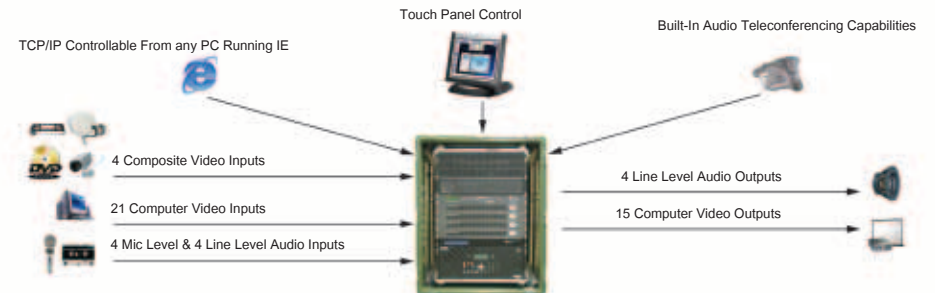

Packaging:

Large AV Case

Molded, weather resistant, OD green case contains Control Processor, four Four Window Video Processors, a Quad Channel Video Scaler, an Audio Mixer and a 32 x 32 RGBHV Matrix Switcher.

Accessory Transport Case 1:

Cables, touch panel and speakers.

Accessory Transport Case 2:

Includes CAT5 TX/RX units and cables.

DRASH ACCESSORIES

DRASH accessories are available to enhance every mission capability. Installation of any DRASH accessory is quick and easy. You can do it yourself, or you can contact a DRASH field representative for onsite support. All DRASH accessories come with a guaranteed five-year warranty for parts and service. Extended support contracts for periodic maintenance, refresher training and field support for deployments and exercises are also available.

DRASH Accessories Include The Following Items:

D-1000B Heater: rugged, lightweight, portable heater that includes an electronic control system.

DRASHLITES: rugged, rust-resistant, rain-tight strip light is available in 2 and 4 light kits.

DRASH Boots: a connection between a vehicle or another DRASH shelter that is light-tight and weather-tight.

Shelter Anchor Bag: used to secure DRASH shelters on a hard surface where staking is impractical.

PDUs: an effective, safe, reliable and efficient way to distribute and share power throughout your system.

Shelter Electrical Kit: includes all lighting and wiring systems designed to fit a specific shelter or complex of shelters.

Trailer Deployment Package: contains consumable and durable parts necessary to carry out scheduled services and minor repairs for up to six months.

Shelter Spare Parts Kit: contains all of the components and tools necessary to carry out field repairs or replace parts.

Connector Sets: provides light-tight connections between DRASH Shelters.

Extreme Weather Kit: used when deployed to climates where heavy snow is expected.

Plenum: used inside shelters to evenly distribute cool or heated air.

Turf Cart: designed to easily transport DRASH gensets and ECUs.

Hard Door: offers users a rigid, user-friendly entranceway into their DRASH facility.







DRASH D-1000B HEATER

Part Number: 1002814
 NSN: 8340-01-467-9165

The D-1000B Heater is rugged, lightweight, rust resistant, shockproof and easy to operate and maintain, providing 99,500 BTUs/hr of dry, clean heat at a rate of 1,020 CFMs. The heater includes an electronic control system that monitors for high heat conditions and flameout, and operates on an external input of 120 VAC, 60 Hz, single-phase power.

- Features:**
- Full safety protection devices, including a safety shut off switch that shuts off upon detecting 100 ppms of Carbon Monoxide content.
 - Operates for 12 consecutive hours without refilling the fuel tank.
 - Can run at temperatures as low as -50°F.*

**Independently tested at the US Army Facility at Picatinny Arsenal, NJ. Note: Arctic Fuel Blend required for temperatures below fuel gel point.*

- Specifications:**
- Weight (Total dry weight without accessories): 167 lbs.
 - Weight (Ducts): 27 lbs. each
 - Dimensions: 53.2" L x 23.8" W x 32.3" H
 - Dimensions (Ducts): 12" D X 15' L
 - Fuel Types: JP8, Diesel
 - CSA Certified, UL Compliant



DRASHLITE

Part Number: H300000-2 (2-Light Kit), H300000-4 (4-Light Kit)
 NSN: 8340-01-513-9672 (2-Light Kit), 8340-01-513-9676 (4-Light Kit)

A rugged, rust-resistant, rain-tight strip light, the DRASHLITE is available in 2-light and 4-light kits. The 2-light kit includes two light fixtures, a cushioned storage bag and an electrical set. The 4-light kit includes four light fixtures, two cushioned storage bags and an electrical set.

- Features:**
- Green, water proof, aluminum housing with molded plastic end caps.
 - Aluminum reflector, slim electronic ballasts (2) and 55-watt twin "U" light bulbs (2).
 - Three-position waterproof toggle switch to allow for single or double bulb operation.
 - Includes a carrying handle, 43" power cord (coiled to prevent unwanted slack), adjustable hanging strap and cushioned carrying bag.
 - Available for 120V/60Hz, 220V/60Hz, and 220V/50Hz.

- Specifications:**
- Individual light fixtures measure 24" x 7.5" x 5.5" and weigh 9.8 lbs.
 - A 2-light kit (with two fixtures and storage bag) measures 30" x 14" x 9" and weighs 22 lbs.



DRASH BOOTS

DRASH Boots are custom designed and manufactured to create a light-tight, weather-tight connection between a vehicle and any DRASH shelter. Each boot's vinyl-coated fabric is fire retardant, mildew resistant, water repellent, abrasion resistant and ultraviolet resistant, and includes blackout in the visual and near infrared spectrum. DRASH Boots are operable in tem-

peratures ranging from -50° to 131°F (-45.5°C to 55°C).

Features:

- Ensures convenient and tactically safe movement from inside a shelter, providing a more effective work or command area than inside a vehicle.

- Vinyl-coated fabric is fire retardant, mildew resistant, water repellent, abrasion resistant, ultraviolet resistant, and includes blackout in the visual and near infrared spectrum.
- Operable in temperatures ranging from -50° to 131°F (-45.5°C to 55°C).
- Five-year warranty for materials and workmanship.

BASIC BOOT DESIGNS:

T-Boot

Attaches to the Truncated, or T Variant, of most C, S, XB and M Series Shelters.

Door Boot

Attaches to the doorway of any DRASH shelter to accommodate most military vehicles.

Boot Wall System

Part Number: SH540-0001T (Tan), SH540-0001G (Green)
Attaches to most DRASH shelter end cap doors or side doors to most common military vehicles or to another DRASH shelter. The additional space provides a small vestibule for increased workspace.

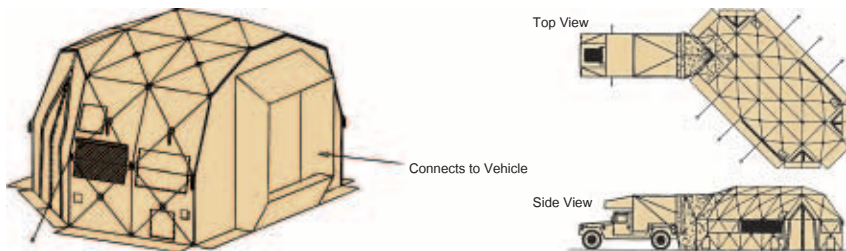

NOTE: DRASH Boots are generally custom-made to accommodate specific functions. To ensure a proper fit, contact your DRASH representative.



SHELTER ANCHOR BAG

Part Number: 1010590

The Shelter Anchor Bag allows users to secure their DRASH shelter or any other equipment placed on a hard surface where staking cannot be accomplished. Featuring a user-friendly design, personnel simply have to position the bag on top of the shelter's skirt, fill it with water or sand and then attach it to the shelter's windlines using two (2) snaps hooks located at either end.

The Shelter Anchor Bag's trapezoid shape and three (3) wooden slats strategically located at the bottom of the bag prevent rolling or any other unplanned movement. A six inch-wide nozzle at the top of the bag allows water or sand to enter or leave the bag with ease. Additionally, the bag is constructed from durable black PVC – ensuring it will withstand harsh field conditions.

Specifications:

- Weight, Filled: 220 lbs
- Weight, Empty: 21 lbs
- Dimensions: 48" L x 15" W x 8" H
- Filling Capacity: 26 gal

POWER DISTRIBUTION UNITS (PDU)



DRASH Impact-Resistant Power Distribution Unit (PDU)

Part Number: 1003506 (60A), 1009355 (100A)

The DRASH Impact-Resistant Power Distribution Unit (PDU) is built to meet U.S. MIL-STD-810G for high and low temperature operation, weather-resistant operation and drop resistance. Featuring a lightweight, one-piece molded design, the unit weighs only 27 lbs. Molded-in handles allow for easy transport and stackability, while power distribution cables with Mil-Spec connectors are available in 25 ft., 50 ft. and 100 ft. lengths. Available in two configurations: 60A and 100A.

Body Construction:

- Molded polyethylene body
- Dielectric rigidity is greater than 5kV
- Dimensions are 22" x 22" x 15"

Electrical Components:

- Branch circuit breaker protection
- 220 V circuits available
- GFI protection
- Pilot light indicates if power is on or off



DRASH Universal Adapter Power Distribution Unit (PDU)

Part Number: 1008600

The DRASH Universal Adapter PDU allows heavy-duty, three-phase equipment lacking standard military connectors to be connected with DRASH power equipment. Constructed from rugged polypropylene, the unit weighs only 15 lbs. and accepts a Mil-Std power input of 120/208 V, 5 Pin. A built-in handle allows for easy transport, while folding legs provide elevation from water, dirt, sand and other less than-ideal surfaces.

Body Construction:

- Rugged polypropylene body
- Dimensions are 22" x 14" x 9"

Electrical Components:

- Mil-Std Power Input, 120/208 V, 5 Pin
- 5x Phase Cable Outputs



SHELTER ELECTRICAL KIT

Provides shelter power distribution for lighting and accessories.

Shelter Electrical Set (TMSS Medium)

Part Number: T2-95205

- Cord, Power, 40 FT, 20A, 120V, 60Hz (1)
- Cord, Power, 15 FT, 15A, 120V, 60Hz (1)
- Power Strip, 4 Outlet, 120V, ISOB (1)
- Outlet, Portable, GFCI, Triple (1)
- Canvass Storage Bag (1)

Shelter Electrical Set (TMSS Large)

Part Number: H300036

- Cord, Power, 6 FT, 20A, 120V, 60Hz (1)
- Cord, Power, 30 FT, 20A, 120V, 60Hz (2)
- Outlet, Portable, GFCI, Triple (2)
- Power Strip, 4 Outlet, 120V, ISOB (2)
- Canvass Storage Bag (1)

Shelter Electrical Set (SMALL)

Part Number: T2-95211

- Cord, Power, 40 FT, 20A, 120V, 60Hz (1)
- Cord, Power, 15 FT, 15A, 120V, 60Hz (1)
- Power Strip, 4 Outlet, 120V, ISOB (1)
- Outlet, Portable, GFCI, Triple (1)
- Canvass Storage Bag (1)

Shelter Electrical Set (MEDIUM)

Part Number: T2-95212

- Cord, Power, 40 FT, 20A, 120V, 60Hz (1)
- Cord, Power, 20 FT, 20A, 120V, 60Hz (1)
- Cord, Power, 15 FT, 15A, 120V, 60Hz (1)
- Power Strip, 4 Outlet, 120V, ISOB (2)
- Outlet, Portable, GFCI, Triple (1)
- Canvass Storage Bag (1)

Shelter Electrical Set (LARGE)

Part Number: T2-95213

- Cord, Power, 40 FT, 20A, 120V, 60Hz (1)
- Cord, Power, 20 FT, 20A, 120V, 60Hz (2)
- Cord, Power, 15 FT, 15A, 120V, 60Hz (1)
- Power Strip, 4 Outlet, 120V, ISOB (3)
- Outlet, Portable, GFCI, Triple (1)
- Canvass Storage Bag (1)



TRAILER DEPLOYMENT PACKAGE

Contains consumable and durable parts necessary to carry out scheduled services and minor repairs for up to six months.

Some common components are*:

- Lower & Upper Radiator Hoses
- Air, Fuel, and Oil Filters
- Contactors, relays and fuses for ECU and Gensets
- Landing Leg

* Specific contents may vary depending on trailer model.



SHELTER SPARE PARTS KIT

Contains components and tools necessary to carry out shelter field repairs or replacement of parts.

C/S/XB Shelter Spare Parts Kit

Part Numbers:

C - 1000895 (Green), 1000896 (Tan)

S - 90223G (Green), 90223T (Tan)

XB - 190223G (Green), 190223T (Tan)

- Interior Looped Keepers (5)
- Exterior Looped Keepers (5)
- Exterior Keepers (5)
- Internal Hub Sets (2)
- Exterior Hub Sets (2)
- Screws #8 1/2 (50)
- Ratchet Screwdriver (1)
- Spanner Wrench (1)
- Blue Strut Pairs (2)
- Green Strut Pairs (2)
- Red Strut Pairs (4)
- Yellow Strut Pairs (4)
- Grommet Spur (1)
- Canvas Bag (1)

M/MX Shelter Spare Parts Kit

Part Numbers: MA100755G (Green), MA100755T (Tan)

- Interior Looped Keepers (5)
- Exterior Looped Keepers (5)
- O-ring for Keepers (5)
- Looped Keepers (3)
- Keepers with O-ring S/XB (2)
- Internal Hub Sets M/MX (4)
- Exterior Hub Sets M/MX (4)
- Internal Hub Sets (2)
- Exterior Hub Sets (2)
- Screws #8x 1/2 (25)
- Screws ¼-15x3/4 #10 (50)
- Ratchet Screwdriver (1)
- Spanner Wrench (1)
- Grommet Spur (1)
- Spare Parts Kit M (1)
- Canopy Pair M/MX (1)
- Blue Strut Pairs M/MX (1)
- Red Strut Pairs M/MX (2)
- Yellow Strut Pairs M/MX (2)
- Blue Strut Pairs XB (1)
- Red Strut Pairs XB (1)
- Yellow Strut Pairs XB (1)
- Green Strut Pairs XB (1)
- Canvas Bag (1)

J Shelter Spare Parts Kit

Part Numbers: JA200565 (Green), JA200585 (Tan)

- Interior Looped Keepers (5)
- Exterior Looped Keepers (5)
- Exterior Keepers (5)
- Internal Hub Sets (4)
- Exterior Hub Sets (4)
- Hub Assy, Float, J Riser (2)
- Nuts for J Hub (50)
- Screws ¼-20x7/8 (50)
- Ratchet Screwdriver (1)
- Spanner Wrench (1)
- Blue Strut Pairs (2)
- Green Strut Pairs (2)
- Red Strut Pairs (4)
- Yellow Strut Pairs (4)
- Grommet Spur (1)
- Canvas Bag (1)



CONNECTOR SETS

Provide a weather and light-tight connection between two shelters regardless of series or model.

	Old "S" Doors sewn in, prior to 2001	New "S" Doors detachable, 2002-present	Old XB Doors, 2001 to 2007 & XBTM doors	New XB Doors, 2007 to present	M/MX End Cap Door	M/MX Side Door	C - T Plate	ST or SI Series	XBT or XBI Series	J Side Door	C Shelter door	M/MX T-end	J- T-Plate
Old "S" Doors sewn in, prior to 2001	93144G 93144T	93144G 93144T	93144G 93144T	1009937 1009938	1009937 1009938	NA	1009937 1009938	T or I Ends go to Boots Only	NA	NA	NA	NA	NA
New "S" Doors detachable, 2002-present	93144G 93144T	93144G 93144T A612200 A612220	93144G 93144T	1009937 1009938	1009937 1009938	NA	1009937 1009938	T or I Ends go to Boots Only	NA	NA	NA	NA	NA
Old XB Doors, 2001 to 2007 & XBTM doors	93144G 93144T	93144G 93144T	93144G 93144T A612160 A612180	100993 1009938 A612160 A612180	1009937 1009938	NA	1009937 1009938	T or I Ends go to Boots Only	NA	NA	NA	NA	NA
New XB Doors, 2007 to present	1009937 1009938	1009937 1009938	1009937 1009938 A612160 A612180	MXA1051G MXA1051T A612160 A612180	MXA1051G MXA1051T	1010341 1010342	MXA1051G MXA1051T	T or I Ends go to Boots Only	NA	MXA1051G MXA1051T	1010937 1010938	NA	NA
M/MX End Cap Door	1009937 1009938	1009937 1009938	1009937 1009938	MXA1051G MXA1051T	MXA1051G MXA1051T	1010341 1010342	MXA1051G MXA1051T	T or I Ends go to Boots Only	NA	MXA1051G MXA1051T	1010937 1010938	NA	NA
M/MX Side Door	NA	NA	NA	1010341 1010342	1010341 1010342	MA100535 MA100135	1010341 1010342	T or I Ends go to Boots Only	1002779 1002780	NA	NA	NA	NA
C - T Plate	1009937 1009938	1009937 1009938	1009937 1009938	MXA1051G MXA1051T	MXA1051G MXA1051T	1010341 1010342	MXA1051G MXA1051T	T or I Ends go to Boots Only		MXA1051G MXA1051T	1010937 1010938	NA	NA
ST or SI Series	T or I Ends go to Boots Only	T or I Ends go to Boots Only	T or I Ends go to Boots Only	T or I Ends go to Boots Only	T or I Ends go to Boots Only	T or I Ends go to Boots Only	T or I Ends go to Boots Only	T End to T End	NA	NA	NA	NA	NA
XBT or XBI Series	NA	NA	NA	NA	NA	1002779 1002780	NA	NA	T End to T End	JA200280 JA200290	NA	NA	will work with T Ends
J Side Door	NA	NA	NA	MXA1051G MXA1051T	MXA1051G MXA1051T	NA	MXA1051G MXA1051T	NA	JA200280 JA200290	2J's + any XBI	NA	JA200280 JA200290	JA200280 JA200290
C Shelter door	NA	NA	NA	1010937 1010938	1010937 1010938	NA	1010937 1010938	NA	NA	NA	1010935 1010936	NA	NA
M/MX T-end	NA	NA	NA	NA	NA	NA	NA	NA	NA	JA200280 JA200290	NA	T to T	will work
J- T-Plate	NA	NA	NA	NA	NA	NA	NA	NA	will work with T Ends	JA200280 JA200290	NA	will work	T to T, MX T End, XBI



EXTREME WEATHER KIT

An Extreme Weather Kits is an optional accessory for the S, XB, and M Series Shelters to be used when deployed to climates where heavy snow is expected and when the shelter will not be heated or maybe left unattended for an extended period of time.



TURF CART

Part Number: 1012920 (Green), 1012850 (Tan)

The DRASH Turf Cart is designed to easily transport both DRASH gensets and ECUs (see page 68). The cart can easily move units weighting up to 1800 lbs. It also features a 20"x20" slide out storage tray capable of holding up to 120 lbs and has four tie down rings to safely secure unit before moving.



PLENUMS

DRASH Plenums evenly distribute cooled or heated air throughout your DRASH Shelter System.



HARD DOOR

Part Number: 1009319

The DRASH Hard Door can be attached to any C, XB, M or J Series end cap door to provide users with a rigid, user-friendly entranceway. The door can also be attached to the DRASH Self Enclosed Annex Lobby (see page 64) to form a complete entry control point.



First introduced in 1902 when James E. Reeves, a Philadelphia firefighter, filed a patent for a flexible stretcher, Reeves EMS has grown to become the brand of choice for today's emergency responder.

Real-Life Solutions for the Emergency Responder

The Reeves EMS brand offers a full line of emergency medical products and accessories, from mobile incident command posts and decontamination systems to patient movement equipment and fatality management.

Reeves decontamination systems feature the latest in cutting edge NBC decontamination technology. Each system can deploy in minutes, is built to withstand extreme conditions and can be equipped with an array of available accessories.

The Reeves line of patient movement equipment, including stretchers, spine boards and extrication equipment, is equally well-known for its quality, durability, and innovative designs.

The Reeves EMS brand also features a line of "turn-key" shelter systems that utilize DRASH shelter technology to create the wide range of facilities responders need while working in the field, including mobile emergency operations centers, medical surge facilities and patient isolation systems.

Superior Quality

All Reeves EMS brand products are manufactured within the United States and adhere to the highest standards of quality and durability. Reeves shelter systems, stretchers and decontamination systems have also gone rigorous testing and continuous product evaluation.

Use and Deployment

Reeves shelter systems have been deployed at incident scenes across the country, including at the 2001 World Trade Center site and in New Orleans following Hurricane Katrina. Shelter systems have also been deployed by the Connecticut Department of Public Health, the City of New Orleans and the National Guard, among others.

Additionally, Reeves decontamination equipment has been deployed by emergency response organizations around the world, including departments of the U.S. Army, Navy, Air Force and Army Reserve, as well as numerous state and local agencies.

Reeves stretchers are in use with numerous federal, state and local organizations, including the FDNY, U.S. Navy and Secret Service.





EMERGENCY RESPONSE SYSTEMS

From mobile incident camps to medical surge facilities, Reeves emergency response systems come in a variety of sizes and configurations to fit any situation in which mobile facilities are necessary for emergency response.

Military-Grade Shelter Technology

Reeves emergency response systems are constructed using parent company DHS Systems' line of Deployable Rapid Assembly Shelters (DRASH) that have been trusted by military forces around the world for more than 25 years. Each DRASH shelter can be set up by minimal personnel and is built to withstand the harshest conditions - from strong winds to extreme temperatures - ensuring that responders can deploy their emergency response systems anywhere, anytime.

Turn-Key Packages

Whether configured as a life support area or casualty collection point, Reeves shelter systems include all the necessary components to provide a total shelter solution during any incident. A full line of supporting accessories - including trailers, generators, lights, environmental control, hard flooring and communications equipment - is also available.

A Wide Range of Applications

Reeves emergency response systems have been used for a number of applications, ranging from medical surge and incident command to mobile patient vaccination and fatality management.

Reeves shelter systems have been purchased by organizations around the country, including the New York City Office of Chief Medical Examiner (NYC OCME), the City of New Orleans, San Bernardino County in California and numerous other federal, state and local agencies.





CASUALTY COLLECTION POINTS



Features:

- Shelter system in which to administer emergency field treatment to victims of disasters or trauma.
- Deployed or taken down by minimal personnel within a matter of minutes.
- 5-Bed and 10-Bed models available.
- 359-519 usable square feet.
- Used by Seton Healthcare in Austin, Texas.
- Basic package includes shelter, heating, cooling and lighting.
- Optional power generation and distribution, hard flooring, patient bedding and medical equipment available.

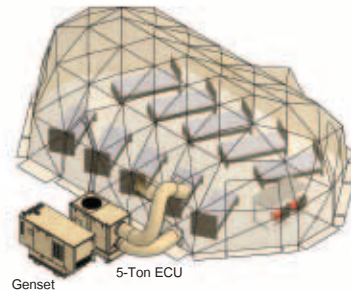

Note: A 10-Bed Casualty Collection Point is shown above. A 5-Bed is also available. Genset, cots and other furniture (as shown) are optional. For information about additional accessories, please contact your Reeves EMS representative.

	5-Bed	10-Bed
Part Number	RHPK0100	RHPK0125
Usable Area (sq. ft.)	359	519
DRASH Shelter System (Tan)	5XB	MX5
Fabric Air Plenum System	1	1
3.5-Ton Mobile ECU	1	-
5-Ton Mobile ECU	-	1
DRASH 4-Light Set w/Electrical Set	1	1

MEDICAL SURGE FACILITIES



Features:

- Shelter system in which to expand existing bed capacities in response to a disaster or emergency situation.
- Deployed or taken down by minimal personnel within a matter of minutes.
- 10-Bed and 25-Bed models available.
- 748-1,285 usable square feet.
- Used by the Connecticut Department of Public Health.
- Basic package includes shelter, heating, cooling and lighting.
- Optional power generation and distribution, hard flooring, patient bedding and medical equipment available.

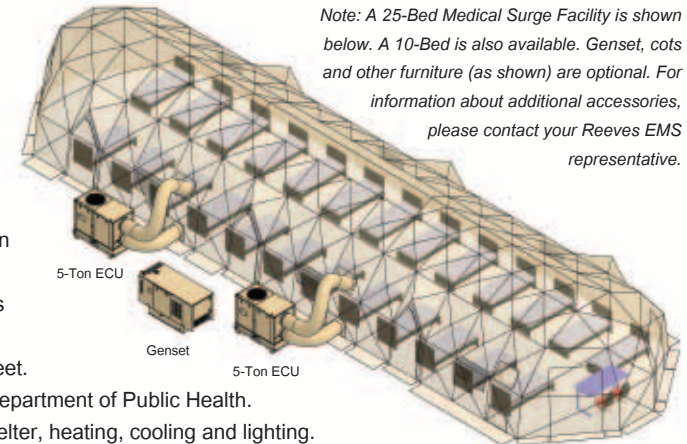

Note: A 25-Bed Medical Surge Facility is shown below. A 10-Bed is also available. Genset, cots and other furniture (as shown) are optional. For information about additional accessories, please contact your Reeves EMS representative.

	10-Bed	25-Bed
Part Number	RHPK0450	RHPK0400
Usable Area (sq. ft.)	748	1285
DRASH Shelter System (Tan)	M	MX5 Center Section (3) MX End Cap (2)
Fabric Air Plenum System	1	2
5-Ton Mobile ECU	1	2
DRASH 2-Light Set w/Electrical Set	1	-
DRASH 4-Light Set w/Electrical Set	1	3

MOBILE VACCINATION SYSTEM



Features:

- Shelter system from which health officials can administer vaccinations in the field.
- Deployed or taken down by minimal personnel within a matter of minutes.
- Up to 442 usable square feet.
- Used by the Hamilton County Health Department in Indiana.
- Basic package includes shelter, bladder and blower system and lighting.
- Optional heating and cooling, power generation and distribution, hard flooring and medical storage equipment available.

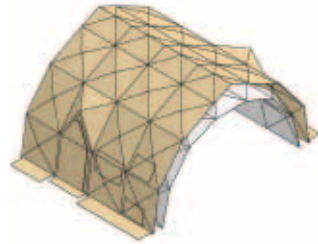

Note: End caps are taken off to allow for drive-thru capability. System comes with end caps to allow for an enclosed system if desired. For information about additional accessories, please contact your Reeves EMS representative.

Mobile Vaccination System	
Part Number	1008295
Usable Area with End Caps (sq. ft.)	442
DRASH Shelter System (Tan)	MX
Small Bladder and Blower System	1
DRASH 4-Light Set w/Electrical Set	1

FATALITY MANAGEMENT CENTERS



Features:

- Serves as a temporary location in the field for the identification, processing, storage and viewing of casualties following a disaster or emergency.
- Deployed or taken down by minimal personnel within a matter of minutes.
- Small, Medium and Large models available.
- 250-902 usable square feet.
- Used by the NYC Office of Chief Medical Examiner (OCME).
- Basic package includes shelter, heating, cooling and lighting.
- Optional power generation and distribution, hard flooring, privacy curtain, 5-foot sectional rollers, mortuary trays, body bags, tables and chairs available.

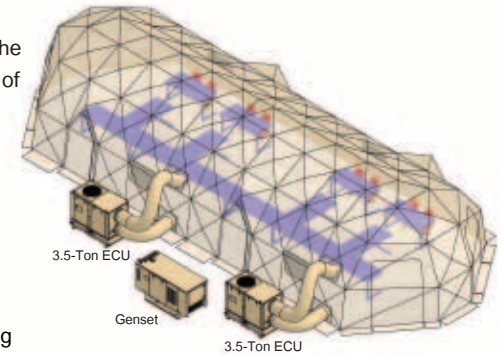

Note: A Large Fatality Management Center is shown above. Small and medium systems are also available. Genset, privacy curtains and roller systems (as shown) are optional. For information about additional accessories, please contact your Reeves EMS representative.

	Small	Medium	Large
Part Number	RHPK0300	RHPK0325	RHPK0425
Usable Area (sq. ft.)	250	414	902
DRASH Shelter System (Tan)	3XB	6XB	MX5 Center Section (2) MX End Cap (2)
Fabric Air Plenum System	1	1	1
3.5-Ton Mobile ECU	1	1	2
DRASH 2-Light Set w/Electrical Set	1	-	-
DRASH 4-Light Set w/Electrical Set	-	2	2

INCIDENT COMMAND POSTS



Features:

- Shelter system from which an incident commander can assign and direct rescue and relief efforts from the field during an emergency or crisis.
- Deployed or taken down by minimal personnel within a matter of minutes.
- Small, Medium and Large models available.
- 250-519 usable square feet.
- Used by San Bernardino County in California.
- Basic package includes shelter, heating, cooling and lighting.
- Optional power generation and distribution, hardened flooring, projectors, screens, chairs and "smart" tables available.

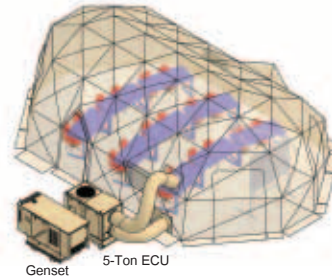

Note: A Large Incident Command Post is shown above. Small and medium systems are also available. Genset, communications equipment and furniture (as shown) are optional. For information about additional accessories, please contact your Reeves EMS representative.

	Small	Medium	Large
Part Number	RHPK0225	RHPK0250	RHPK0275
Usable Area (sq. ft.)	250	359	519
DRASH Shelter System (Tan)	3XB	5XB	MX5
Fabric Air Plenum System	1	1	1
3.5-Ton Mobile ECU	1	1	-
5-Ton Mobile ECU	-	1	1
DRASH 2-Light Set w/Electrical Set	1	-	-
DRASH 4-Light Set w/Electrical Set	-	1	1

LIFE SUPPORT AREAS



Features:

- Serves as temporary housing in the field during any emergency.
- Deployed or taken down by minimal personnel within a matter of minutes.
- 10-Bed and 20-Bed models available.
- 519-902 usable square feet.
- Used by FEMA in response to Hurricane Katrina.
- Basic package includes shelter, heating, cooling and lighting.
- Optional power generation and distribution, hard flooring, cots and bedding available.

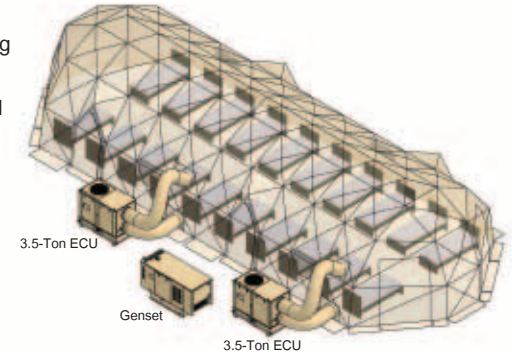

Note: A 20-Bed Life Support Area is shown above. A 10-Bed is also available. Genset, cots and other furniture (as shown) are optional. For information about additional accessories, please contact your Reeves EMS representative.

	10-Bed	20-Bed
Part Number	RHPK0350	RHPK0375
Usable Area (sq. ft.)	519	902
DRASH Shelter System (Tan)	MX5	MX5 Center Section (2) MX End Cap (2)
Fabric Air Plenum System	1	1
3.5-Ton Mobile ECU	-	2
5-Ton Mobile ECU	1	-
DRASH 4-Light Set w/Electrical Set	1	2

RESPONDER SERIES



Features:

- Ideal for use as decontamination, hygiene, modesty, triage and rehabilitation areas.
- Deployed or taken down by minimal personnel within a matter of minutes.
- No power or air required to erect.
- Each shelter comes standard with a transport-style duffel bag, repair kit, push poles, wind lines and a steel pin stake set.

Sizes and Dimensions:

DRASH Responder Series Shelters come in four basic sizes: small, medium, large and extra large. Each shelter has one of four standard widths ranging from 6.8' to 14.5' and varies in lengths from 5' to 24'.

DIMENSIONS

DRASH Shelter Model	Size	Exterior	Interior	Weight (lbs.)
AD11SECB	Small	8.8'W x 5'L x 11'H	6.8'W x 5'L x 8.3'H	115
AD12XBECB	Medium	11.8'W x 8'L x 10.5'H	10'W x 8'L x 8.8'H	160
AD13XBECB	Medium	11.8'W x 12'L x 10.5'H	10'W x 12'L x 8.8'H	180
AD14XBECB	Medium	11.8'W x 16'L x 10.5'H	10'W x 16'L x 8.8'H	225
AD15XBECB	Medium	11.8'W x 20'L x 10.5'H	10'W x 20'L x 8.8'H	245
AD16XBECB	Medium	11.8'W x 24'L x 10.5'H	10'W x 24'L x 8.8'H	265
AD2SECB	Large	13.5'W x 10'L x 11'H	11.5'W x 10'L x 8.3'H	155
AD3SECB	Large	13.5'W x 15'L x 11'H	11.5'W x 15'L x 8.3'H	235
AD4SECB	Large	13.5'W x 20'L x 11'H	11.5'W x 20'L x 8.3'H	265
AD5SECB	Large	13.5'W x 25'L x 11'H	11.5'W x 25'L x 8.3'H	295
AD6SECB	Large	13.5'W x 30'L x 11'H	11.5'W x 30'L x 8.3'H	325
AD2XBECB	Large	13.5'W x 8'L x 10.5'H	14.5'W x 8'L x 8.8'H	205
AD3XBECB	Extra Large	16.5'W x 12'L x 10.5'H	14.5'W x 12'L x 8.8'H	210
AD4XBECB	Extra Large	16.5'W x 16'L x 10.5'H	14.5'W x 16'L x 8.8'H	215
AD5XBECB	Extra Large	16.5'W x 20'L x 10.5'H	14.5'W x 20'L x 8.8'H	295
AD6XBECB	Extra Large	16.5'W x 24'L x 10.5'H	14.5'W x 24'L x 8.8'H	400

EMERGENCY RESPONSE SYSTEMS ACCERSSORIES

Please see website for additional information.



3.5-Ton Mobile ECU

1008946

The self-contained, portable DRASH 3.5-Ton Environmental Control Unit (ECU) offers air conditioning, area cooling and portable heating all in one easy-to-use package.

BTUs: 42,000

Dimensions: 35"W x 48"L x 45"H

Weight: 398 lbs.

Standard Color: Light Green



5-Ton Mobile ECU

1008080

This self-contained, portable DRASH 5-Ton Environmental Control Unit (ECU) offers air conditioning, area cooling and portable heating all in one easy-to-use package.

BTUs: 60,000

Dimensions: 35"W x 60"L x 47"H

Weight: 580 lbs.

Standard Color: Green



Military Style Cots

Able to support 350-plus pound load, Military-Style Cots set up and break down with ease. Military-Style Cots are available in Standard, Mid-Size and Oversize models. A carry bag with shoulder strap makes for easy transport.

Standard Cot - RDA30405

Dimensions: 25.5"W x 74"L x 16"H

Weight: 17 lbs.

Mid-Size Cot - 1002323

Dimensions: 28"W x 78"L x 18"H

Weight: 20 lbs.

Oversize Cot - RDA30410 (Oversize)

Dimensions: 32"W x 82"L x 18"H

Weight: 24 lbs.

Mid-Size Military Style Cot shown. Available in green only.



Medical Needs Cot

RDA30695

Featuring a super comfortable, heavy-duty design, the Medical Needs Cot includes a heavy-duty aluminum frame and fabric deck measuring 27"W x 75"L x 17"H - allowing it to hold more than 350 lbs.

Dimensions: 27"W x 75"L

Height: 17.25" (flat); 32.5" (elevated)

Weight: 27 lbs.

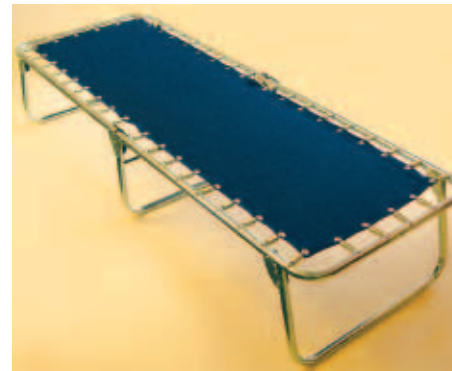

Bi-Fold Spring Cot

RDA30690

With a load capacity of 300 pounds, the Bi-Fold Spring Cot is lightweight, easy to transport and able to set up and fold quickly and easily. The frame is constructed of chromed tubular steel, while a heavy-duty nylon canvas mat suspended by 44 springs allows users to relax and sleep with ease.

Dimensions: 72"L x 26"W x 16"H

Weight: 27 lbs.



Mil-Spec Army Cot

1008143

With a load capacity of 500-plus pounds, the Mil-Spec Army Cot has passed all Mil-Spec requirements - making it one of the toughest cots in the field. Cot material is made from 600 x 300D Oxford Nylon with PVC coating and includes heavy duty nylon end caps for added rigidity. Comes with its own custom carry bag.

Dimensions: 78"L x 28"W x 18"H

Weight: 27 lbs.



Westcot 400 Medical Bed

RDS0125

The Westcot 400 Medical Bed can hold more than 400 pounds of weight. Features include a stow-on-board IV pole, water-proof, anti-microbial, reinforced vinyl mattress cover and 5-position head elevator with locking cord. An active patient care (APC) version of the medical bed is also available.

Dimensions: 32"W x 80"L x 28"H

Weight: 32 lbs.

Westcot PediBed

1009707

The Westcot PediBed can be used alone or attached to most medical beds used in the field today to accommodate infants up to six months old.

Dimensions: 32"L x 32"W x 20"H

Weight: 10 lbs.

Hanging Drawer for Westcot Beds

RDS0126

Attaches to a bed's front leg brace and can hold a clip board for patient records and triage flag to designate patient condition.

Westcot Mattress

RDS0127

This two inch comfort foam mattress can be used with Westcot 400 and Westcot 400 APC beds. It meets new Federal Standard 1633 for flammability and can easily be decontaminated.

Safety Rails for Westcot Beds

RDA30948

Optional components that can be attached to Westcot 400 and APC Beds during the production process. Sold as a set of 4.

Westcot Disposable Linen Set

RDA30945

This disposable linen set for Westcot 400 and Westcot 400 APC beds includes a fitted sheet, flat sheet, pillow case, pillow and blanket. All products are sold as sets or available in bulk.

Westcot 8-10 Bed Rolling Racks

Available in three versions, Rolling Racks easily transfer folded Westcot beds. Able to travel easily on carpet, vinyl, wood and concrete flooring.



Westcot Dustcover - 1003536

Dust covers are available with hook and loop closures to keep beds dry and dirt free.

Westcot 8 Bed Rolling Rack - 1003350

Built to accommodate 8 Westcot 400 APC Medical Beds.

Dimensions: 37"D x 43"W x 82"H

Empty Rack Weight: 155 lbs.

Westcot 10 Bed Rolling Rack - 1003351

Built to accommodate 10 Westcot 400 Medical Beds.

Dimensions: 37"D x 43"W x 82"H

Empty Rack Weight: 155 lbs.

Westcot 8 Bed Rolling Rack - 1003563

The 70 inch-high, 8 bed rolling rack allows Westcot 400 bed and surge cots to be transferred on the back of cargo trailers.

Dimensions: 37"D x 43"W x 70"H

Empty Rack Weight: 155 lbs.

Linen Set

RDA30948

Maximize patient safety and comfort in the field with this practical and affordable Linen Set.

The Set includes:

- Two cot sheets.
- 54" x 72" polar fleece acrylic blanket.
- Pillow case made of cotton-polyester blend.
- Heat and cooling outputs of 60,000 BTU
- 18" x 12" 100% polyester fiber pillow.

All items are vacuum-packed in a poly bag.

Weight: 4.3 lbs.

Color: White



Emergency Blankets

These emergency blankets are made to provide comfort and safety to both patients and personnel in cooler environments.

Dimensions: 60"W x 90"L

Weight: 2.4 lbs.



100% Polyester Blend (Blue)

RDA30710

Sold and wrapped individually.

30% Wool and Polyester Blend (Light Blue)

RDA30715

Sold in bales of 30.

70% Wool and Polyester Blend (Grey)

RDA30720

Sold in bales of 24.

Inflatable Cot Pillows

RDA30705

The Inflatable Cot Pillow features adjustable inflation and a hypo-allergenic polyester over PVC construction. It takes up very little room when stored flat or rolled. Sold in case of 50.

Weight Per Case: 3.6 lbs.

Standard Color: White



Stuffed Cot Pillow

RDA30700

Made from 100% polyester fiber, the Stuffed Cot Pillow offers the ideal way to add more comfort to patient and personnel bedding in the field.

Dimensions: 19"W x 25"L

Weight: 0.8 lbs.



Uni-Sex Hygiene Kit

1004236

Designed for 3-4 day use, the Uni-Sex Hygiene Kit includes toothpaste, a toothbrush, soap, a washcloth, shampoo, a comb, deodorant, lotion, a razor, shave gel and a pack of tissues. Sold as a case of 30 kits.

Weight: 30 lbs.



DECONTAMINATION SYSTEMS AND ACCESSORIES

Reeves decontamination systems and accessories use the latest in NBC decontamination technology to ensure that responders have tools they can trust during any hazmat situation.

Reeves Decontamination Systems

Reeves decontamination systems utilize Deployable Rapid Assembly Shelter (DRASH) technology to deploy in any terrain and withstand the harshest environmental conditions. Able to be set up by two to four personnel in just minutes, each Reeves decontamination system includes a transport-style duffel bag, repair kit, push poles, wind lines and a steel pin stake set.

State-of-the-Art Accessories

Select decontamination systems come equipped with a full line of decon accessories - including an integrated plumbing package, berm, elevation grids, water pump, roller system and water supply adapter kit. Multiple showerheads and spray wands supply the water flow necessary for thorough decontamination, and lane division curtains provide modesty between sexes.

Other accessories, such as patient tracking tools, remains movement equipment, heating and lighting are also available.





DECONTAMINATION SYSTEMS



Individual Reeves Hospital Response



2/3-Lane First Response



3 Lane First Response

Part Number (color)	RDPK0001 (Blue)	RDPK0009 (Blue)	RDPK0010 (Blue)
Description	6.8'W x 5'L x 8.3'H system for one to two ambulatory patients or one non-ambulatory patient	11.5'W x 15'L x 8.3'H system for male and female ambulatory and non-ambulatory patients	14.5'W x 16'L x 8.8'H system for male and female ambulatory and non-ambulatory patients
Total System Weight	210 lbs. / 95.3 kg	1,500 lbs. / 680.4 kg	1,650 lbs. / 748.4 kg
Plumbing	1-Line Integrated Plumbing Package - 4 showerheads / 2 red spray wands	2-Line Integrated Plumbing Package -8 showerheads / 2 black spray wands / 2 red spray wands	2-Line Integrated Plumbing Package -8 showerheads / 2 black spray wands / 2 red spray wands
Lane Curtain	2-Lane Package	3-Lane Set	3-Lane Set
Collapsible-Wall Primary Containment Berm	9'W x 6'L x 8"H	13'W x 14'L x 8"H	13'W x 22'L x 8"H
Patient Roller System	N/A	16' Collapsible	16' Collapsible Patient Roller System
Patient Elevation Grid (2'W x 5'6"L x 3.5"H)	Three (3)	N/A	N/A
Patient Elevation Grid (2'W x 8'L x 3.5"H)	N/A	Four (4)	N/A
Patient Evaluation Grid (3'W x 8"L x 3.5"H)	N/A	Four (4)	Eight (8)
30 GPM Submersible Water Pump w/ 25-foot, 1 1/2" Discharge Hose	One (1)*	One (1)*	One (1)*
Multi-Fuel Water Heater w/ Decon Solution Injection System	N/A	425,000 BTU, up to 28 GPM water heater*	425,000 BTU, up to 28 GPM water heater*
35-foot, 1/2" Suply Hoses w/ Cam Lock Fittings	One (1) Red	One (1) Red, One (1) Black	One (1) Red, One (1) Black
Water Supply Adapter Kit	One (1)	One (1)	One (1)
Shelter Exterior Dimensions	8.8 W x 5 L x 11 H (ft) 2.6 W x 1.5 L x 2.5 H (m)	13.5 W x 15 L x 11 H (ft) 4.1 W x 4.6 L x 3.4 H (m)	16.5 W x 16 L x 10.5 H (ft) 5.1 W x 4.9 L x 3.2 H (m)
Shelter Interior Dimensions	6.8 W x 5 L x 8.3 H (ft) 2 W x 1.5 L x 2.5 H (m)	11.5 W x 15 L x 8.3 H (ft) 3.5 W x 4.6 L x 2.5 H (m)	14.5 W x 16 L x 8.8 H (ft) 4.4 W x 4.9 L x 2.7 H (m)

* EU models available, please contact DHS International representatives for more information.

DECONTAMINATION ACCESSORIES

Please see website for additional information.

425,000 BTU G2 Water Heater

RDHW0003; With Solution Injection System: RDHW0004

Reeves G2 multi-fuel, self-heating water system is portable, easy to maneuver and built for field use. The unit is an ideal way to supply multiple decontamination showers or multiple field showers and sinks with heated water, thus increasing the safety and comfort of both patients and personnel. It is thermostatically-controlled, has inline GFCI protection, a fuel filter with water separator and a built-in anti-scald protection device. It has a flow rate of up to 28 gallons per minute and a 10-gallon on-board fuel tank with drain plug. The heater's motor burner is a 1/4 hp, 120 V, 60hz, 1 ph and runs at 3450 rpm. An optional solution injection system is also available.



Dimensions: 47"L x 30"W x 40"H

Weight*: 445 lbs. (without hoses); 465 lbs. (with hoses)

Standard Color: Black

* Item weight increases by five pounds with mobile injection unit. EU models available, please contact DHS International representatives for more information.

105,000 BTU Pro-100 Propane Water Heater

RDHW0025

The 105,000 BTU Pro-100 Propane Water Heater is portable, lightweight, and designed for field use. The unit can be connected to any water supply to provide up to 6 gallons of heated water per minute to one (1) or two (2) person decontamination showers, hygiene showers or hygiene sinks for increased safety and comfort in the field. Its compact, self-contained design does not require electricity and is easy to transport.



Dimensions: 13" x 14" x 24" (cart 40" high)

Packed Dimensions: 37" x 19" x 21" (water heater); 26" x 21" x 41" (transport cart)*

Weight: 130 lbs. with cart

* Water heater and transport cart packed separately.

Reeves Box-Style Waste Water Bladders



Reeves Waste Water Bladders safely store contaminated run-off water to prevent contamination of the surrounding environment. Constructed of

PVC-coated 28 oz. heavy-duty Panama weave Rip-Stop woven polyester, each bladder's seams are heat seal welded and 1.5" overlapped to fur-

ther ensure maximum strength. Various sizes are available to hold 110-10,000 gallons of water. A standard field repair patch kit is also included.

Item No.	RDB0001	RDB0002	RDB0003	RDB0004	RDB0005	RDB0006	RDB0007	RDB0008
Capacity	110g / 400L	150g / 570L	300g / 1140L	600g / 2,300L	1,200g / 4,500L	1,800g / 6,800L	2,500g / 9,500L	3,000g / 11,300L
Weight*	25 lbs.	28 lbs.	35 lbs.	45 lbs.	65 lbs.	80 lbs.	95 lbs.	105 lbs.
Filled Dim.	3.3' x 5' x 12"	4' x 5' x 12"	4' x 6' x 20"	5' x 8.3' x 23"	6' x 12.4' x 26"	7.5' x 15' x 26"	7' x 19' x 30"	8' x 17.5' x 34"
Ship. Dim.	11" x 11" x 23"	11" x 11" x 24"	12" x 12" x 24"	14" x 14" x 28"	15" x 16" x 30"	18" x 18" x 32"	20" x 20" x 35"	22" x 22" x 36"

Reeves Box-Style Fresh Water Bladders



Reeves Fresh Water Bladders store water that can be pumped into hygiene showers and sinks for use in the field. Each bladder is constructed

from the same durable materials as Reeves Waste Water Bladders. Various sizes are available to hold 110-10,000 gallons of water. A stan-

dard field repair patch kit is also included.

Item No.	RDB00031	RDB00032	RDB00033	RDB00034	RDB00035	RDB00036	RDB00037	RDB00038
Capacity	110g / 400L	150g / 570L	300g / 1140L	600g / 2,300L	1,200g / 4,500L	1,800g / 6,800L	2,500g / 9,500L	3,000g / 11,300L
Weight*	25 lbs.	28 lbs.	35 lbs.	45 lbs.	65 lbs.	80 lbs.	95 lbs.	105 lbs.
Filled Dim.	3.3' x 5' x 12"	4' x 5' x 12"	4' x 6' x 20"	5' x 8.3' x 23"	6' x 12.4' x 26"	7.5' x 15' x 26"	7' x 19' x 30"	8' x 17.5' x 34"
Ship. Dim.	11" x 11" x 23"	11" x 11" x 24"	12" x 12" x 24"	14" x 14" x 28"	15" x 16" x 30"	18" x 18" x 32"	20" x 20" x 35"	22" x 22" x 36"

DECONTAMINATION ACCESSORIES

Please see website for additional information.

Reeves Water Supply Adapter Kit

RDHW0020

Allows users to flow water from a hydrant or garden hose outlet through a Reeves heating system or directly into a Reeves decontamination system.

Dimensions: 20" L x 12" W x 7" H

Weight: 9 lbs.



Elevation Grids

Prevents patients and personnel from coming in contact with contaminants in the containment area.

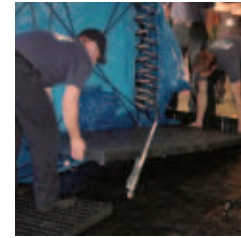

Item No.	Dimensions	Weight
RDFG0001	28"W x 40"L x 6"	22 lbs.
RDFG0002	2'W x 3'L	12 lbs.
RDFG0003	2'W x 5.5'L	21 lbs.
RDFG0004	3'W x 5.5'L	31 lbs.
RDFG0005	2'W x 8'L	30 lbs.
RDFG0006	3'W x 8'L	45 lbs.

Reeves Bladder Retrofit/Adapter Kit

RDPK0525

Allows for a 1 1/2" NST fire hose and a 3/4" garden hose to be connected to the inlet or outlet of any Reeves Box-Style Bladder made prior to 05/2007.

Dimensions: 14"W x 6"L x 5"H

Weight: 5 lbs.

Color: Red



Collapsible-Wall Primary Containment Berms

Item No. assigned according to individual custom made product.

Instantly deployable 8" and 12" berms collect contaminated run-off.

Dimensions: custom made by square foot.

Containment Volume of 8" Wall Models: 5.61 Gallons Per Square Foot

Containment Volume of 12" Wall Models: 7.48 Gallons Per Square Foot

Deluxe Berm Repair Kit

RDCB0017

Kit includes vinyl cement, repair material, a heat gun with slotted heat spreader, a 2" single-arm silicon seam roller, stainless steel scissors, an industrial grade utility knife, sand paper and repair instructions.

Weight: 15 lbs.



30 GPM Submersible Water Transfer Pump*

RDP0001

Pump drains contaminated water contained in system. It includes a 25 foot, 1 1/2" discharge hose.

Dimensions: 12"W x 12"L x 14"L

Weight: 20 lbs.



50-Foot Fire Hose

RDA0051

Features double jacket construction, rubber lining and a test pressure of 400psi.

Weight: 18 lbs.

Color: White



Reeves Collapsible Patient Roller System



The Reeves Collapsible Patient Roller System allows non-ambulatory patients to roll easily through the decontamination process on any standard wooden or plastic backboard. Despite having a weight capacity of 300 pounds per linear foot, the system collapses to a fraction of its deployed length. The system is available in models ranging from eight to 24 feet in length and rollers can be linked together to form a longer system if needed. Each model can also be adjusted from 32" to 44" in height.

Description	8 Foot	12 Foot	16 Foot	20 Foot	24 Foot
Item No.	RDR0001	RDR0002	RDR0003	RDR0004	RDR0005
Dimensions Expanded	8'L x 2'W	12'L x 2'W	16'L x 2'W	20'L x 2'W	24'L x 2'W
Dimensions Collapsed	2.7'L x 2'W	3.8'L x 2'W	4.8'L x 2'W	5.9'L x 2'W	7'L x 2'W
Weight	185 lbs.	255 lbs.	310 lbs.	360 lbs.	410 lbs.

5-Foot Rigid-Frame Sectional Roller System

RDR0007



The Reeves 5-Foot Sectional Roller System allows non-ambulatory patients to roll easily through the decontamination process on any standard pole litter, backboard or without them. Constructed of corrosion-resistant aluminum and featuring folding legs and an adjustable height of 34" to 43," this roller system can also be interlocked to form a longer system.

Dimensions: 2'W x 5'L

Weight: 76 lbs.



QWIK-COVER

Provide patient cover up and safe storage for his/her clothing and personal valuables before entering the decontamination area. It also provides dry off, clean cover up and foot protection before exiting the decontamination area. Available in 3 variants: Pre-Decon, Post-Decon, or a Combo kit that includes both Pre and Post.

QWIK-COVER Pre-Decon Kits

Youth Size: RDPW0210
 Adult Size: RDPW0215
 Large Adult Size: RDPW0220

QWIK-COVER Post-Decon Kits

Youth Size: RDPW0225
 Adult Size: RDPW0230
 Large Adult Size: RDPW0235

QWIK-COVER Combo Kit

Youth Size: RDPW0240
 Adult Size: RDPW0245
 Large Adult Size: RDPW0250



SECUR-ID Decon Property

Safely and securely stores a patient's outer garments, shoes and personal possessions for easy tracking during the decontamination process. Sold in bundles of 50. Available in small or large.

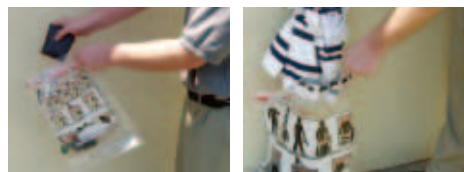

Small: RDPW0205

Large: RDPW0200

Waterproof Triage Tags

RDA0036

Provides first responders with a tool to identify, process, and triage contaminated patients. Sold in packs of 50.

Weight per Pack: 1 lb.



500-Watt Wobble Light

RDL0006

Bright, durable and virtually indestructible, the 36" tall Wobble Light is a self-righting, work light.

Dimensions: 18"L x 18"W x 36"H

Weight (packaged): 25 lbs.

Standard Color: Yellow



1200-Watt Tripod Light

RDL0005

Ideal for scene lighting during nighttime emergency response operations.

Packed Dimensions: 12.3"L x 12.8"W x 28"H
 Packed Weight: 27 lbs.

Standard Color:

Orange



50-Watt Overhead Lights

RDL0001 Dead-End

RDL0002 Stringable

RDL0004 Hardened Case (Lights sold separately.)

Meeting U.S. standards for water-resistant portable lighting, Reeves 50-Watt Stringable or Dead-End Overhead Lighting is a cost-efficient bright light that can go anywhere you need to be.



Wheeled Litter Carrier

RDS0003

Hand cart to move an injured person over terrain not accessible by vehicles. With a weight capacity of 500 lbs., the cart is made of a heavy-duty but lightweight aluminum and folds down to a compact footprint for easy transport and storage.

Dimensions:

Folded, no axle or wheels: 8"H x 39"L x 24"W;

Open with axle & wheels: 28"H x 35"L x 28"W

Weight: 45 lbs.

Wheel: Standard non-puncture wheels (20"H x 2"W)

Options: Height Extenders*, Height Adjustment Platform, IV Rod, Wheel Locks and Rigid Mesh Decon Litter

*A military-version of the Wheeled Litter Carrier with 4" height extenders with wheel locks (part number 1009691) is also available.

Body Bags

Transfer remains in dignified manner available in three variants.

Lightweight, Disposable Adult Body Bag

RSBW001 (White)

Heavy-Duty Adult Body Bag with Viewing Window

RDA30810 (Black)

Pediatric Body Bag

RSBB003 (Black)



STRETCHERS AND IMMOBILIZATION

Since its first stretcher was introduced more than 100 years ago, the Reeves EMS line of patient movement equipment has grown to become known around the world for its quality, durability, and innovative designs.

Reeves EMS brand patient movement equipment - from stretchers and spine boards to extrication equipment - are built for emergency responders. Constructed from some of the most durable materials available today, Reeves patient movement equipment is lightweight but strong enough to hold approximately 1,000 pounds, providing the right support during any situation.

The line's most popular product is the Reeves Sleeve, which is designed for rapid patient immobilization during transport and can be used for vertical or horizontal extrication or confined space rescue. Also well-known is the Reeves Flexible Stretcher, which allows emergency responders to maneuver a patient around corners or on stairways where there would normally not be any room for traditional rigid stretchers.

Specialty stretchers, including the Reeves Stadium Stretchair - a unique stretcher designed to quickly transport victims from stadiums, sport facilities, arenas, theatres or anywhere else multiple steps may create problems when removing patients - are available as well.





REEVES SLEEVE



In use with first responders, government agencies and armed forces around the world, the Reeves Sleeve is one of the most trusted stretchers available today. The Reeves Sleeve, which is constructed from lightweight yet durable material, offers the perfect solution to immobilize patients with spinal or neck injuries and extricate patients from tight spaces.

Having undergone extensive testing, the Reeves Sleeve has proven capable of carrying in excess of 1,000 pounds. It comes in three basic variations: the Reeves Sleeve 122, Reeves Sleeve II and Reeves Sleeve Dragable. All three stretchers have the following features in common:

- Constructed of lightweight 18 oz. vinyl-coated polyester that can be easily washed with soap and water, is highly resistant to acids and alkali, and is unable to be penetrated by liquids.
- Material tensile strength is 400 x 400 lbs./inch; tear torque is 160 lbs. x 95 lbs.
- Multiple padded carry handles allow personnel to transport a patient with ease. Handles are made with 3" polypropylene web with 2" reinforced webbing with foam.
- Five (5) chest and leg straps with buckles and a "fail-safe" strap are added for additional security.
- One (1) vertical lift point and four (4) horizontal lift points for helicopter hoist capability allow the Reeves Sleeve to hoist patients from any angle. A storage pocket for the hoist cables is built into the Sleeve. Lift rings carry 5,000 lbs vertically and 1,250 lbs. horizontally.
- Nylon seat belt webbing tested at 6,000 lbs.
- Includes removable Velcro head-securing blocks, adjustable head and chin-securing straps, a chest and arm-securing flap with Velcro, a leg-securing flap with Velcro and a spine board compartment for added strength and rigidity.



Reeves Sleeve 122



Reeves Sleeve II



Reeves Sleeve Dragable

	Reeves Sleeve 122	Reeves Sleeve II	Reeves Sleeve Dragable
Product Number/Colors*	RSS0005 (Orange); RSS0031 (Black)	RSS0014 (Orange); RSS0027 (Black)	RSS0051 (Orange)
Descriptions	The original Reeves Sleeve. Immobilizes patients with spinal and neck injuries. Allows patient to be extricated out of tight spaces.	Modified from the Reeves Sleeve 122 stretcher to include 10 padded carry handles instead of six, and a reinforced bottom for added strength. Allows for optimal maneuvering through tight places, such as on board a ship.	Modified from the Reeves Sleeve 122 stretcher to include a specially coated nylon, plastic bottom, which allows for dragging through rough terrain. Also includes heavy-duty metal press-and-release buckles.
Dimensions	Open: 73"L x 24"W; Closed: 24"L x 12"W x 5"H	Open: 73"L x 24"W; Closed: 24"L x 12"W x 5"H	Open: 77"L x 27"W; Closed: 28"L x 18"W x 10"H
Weight	15 lbs.	16 lbs.	17 lbs.
Load Capacity	1,000 lbs.	1,000 lbs.	1,000 lbs.
Removeable Hardwood Slats	One (1)	One (1)	One (1)
Ergonomically Placed Handles	Four (4)	Four (4)	Four (4)
Patient Security Straps	Six (6)	Ten (10)	Six (6)
Replacement Parts	Head Blocks, Transport Bag, Head and Chin Strap Set, Buckles	Head Blocks, Transport Bag, Head and Chin Strap Set, Buckles	Head Blocks, Transport Bag, Head and Chin Strap Set, Buckles

* Other variations and colors available according to customer requests.

Accessories

Reeves Sleeves can be outfitted with a wide range of optional accessories and replacement components - including transport bags, head blocks, chest and leg extenders and head and chin straps.

Each stretcher can also be repaired with replacement buckles and chest, leg and "fail-safe" straps as needed. To learn more, contact your Reeves EMS representative.



Reeves Sleeve Transport Bag

RSS0039 (Orange); RSS0054 (Black)

The Reeves Sleeve Transport Bag allows Reeves Sleeve 122 or Reeves Sleeve II stretchers to be transported with ease from one location to the next. It is constructed of lightweight, 18 oz. vinyl-coated polyester that can easily be washed with soap and water, is highly resistant to acids and alkali, and is unable to be penetrated by liquids.

Dimensions: 34" L x 18.5" W

Weight: 1.4 lbs.



Reeves Sleeve Chest and Leg Extenders

RSS0050

The Reeves Sleeve Chest and Leg Extenders Set allows Reeves Sleeve stretchers to accommodate larger patients. The set includes one (1) chest extender and one (1) leg extender. Please note this item is an option and not included with a standard order.

Dimensions:

Leg Extender: 29" L x 25.5" W

Chest Extender: 26.5" L x 17.5" W

Weight per Set: 1.5 lbs.



Head and Chin Straps

RSS0049 (Orange)

Constructed from 18 oz. vinyl and Velcro, the Reeves Sleeve Head and Chin Strap Set helps secure a patient's head during transport. Each set includes one (1) head strap and one (1) chin strap.

Dimensions: 27.5" L x 2.5" W

Weight per Set: 2 oz.



Reeves Sleeve Head Blocks

RSS0026 (Orange)

Reeves Sleeve Head Blocks secure a patient's head while being transported on a Reeves Sleeve 122 or Reeves Sleeve II stretcher. They are constructed of lightweight, 18 oz. vinyl-coated polyester that can easily be washed with soap and water, is highly resistant to acids and alkali, and is unable to be penetrated by liquids. Sold in pairs.

Dimensions: 9.5" L x 5.5" W x 4" H

Weight: 5 oz. (10 oz. per set)

FLEXIBLE STRETCHERS

Reeves Flexible Stretchers allow the emergency responder to maneuver a patient around corners or on stairways where there would normally not be any room for traditional rigid stretchers. Constructed from lightweight 18 oz. vinyl-coated polyester, Reeves Flexible Stretchers are easily washed with soap and water, and highly resistant to acids, alkali and liquids. Hardwood slats positioned between two layers of fabric provide strength and rigidity, while three two-inch polypropylene web patient security straps provide maximum immobilization.

					
	101 Stretcher	103 Heavy Duty Stretcher	104 Mass Casualty Stretcher	105 Stretcher w/ Sealed Body Cover**	106 Heavy Duty Stretcher w/ Sealed Body Cover *
Product Number/Colors*	RSS0003 (Orange), RSS0006 (Gray), RSS0037 (Black)	RSS0004 (Orange), RSS0007 (Gray), RSS0060 (Black)	RSS0008 (Orange), RSS0011 (Gray), RSS0064 (Black)	RSS00012 (Gray)	RSS0013 (Gray), RSS0038 (Orange)
Descriptions	An easily conveyable patient transport device. Flexible design allows for maneuvering around corners or on staircases.	An easily conveyable patient transport device for larger patients. Measures 10" wider than 101 stretcher, and includes 10 handles to allow multiple personnel to lift patient.	An easily conveyable patient transport device used for mass casualty incidents. Compact design allows one person to carry up to 10 stretchers at a time.	An easily conveyable patient transport device with cover that zips to form a sealed transport case. Flexible design allows for maneuvering around corners or on staircases.	An easily conveyable patient transport device for larger patients with cover that zips to form a sealed transport case. Measures 10" wider than 105 stretcher, and includes 10 handles to allow multiple personnel to lift patient.
Dimensions	Open: 78"L x 28"W; Closed: 58"L x 6"W	Open: 79"L x 38"W; Closed: 64"L x 8"W	Open: 78"L x 28"W; Closed: 35"L x 6"W	Open: 78"L x 28"W; Closed: 58"L x 8"W	Open: 79"L x 38"W; Closed: 64"L x 8"W
Weight	15 lbs.	16 lbs.	13 lbs.	17 lbs.	19 lbs.
Load Capacity	700 lbs.	1,000 lbs.	1,000 lbs.	700 lbs.	1000 lbs.
Removeable Hardwood Slats	Five (5)	Seven (7)	Three (3)	Five (5)	Seven (7)
Ergonomically Placed Handles	Six (6)	Ten (10)	Six (6)	Six (6)	Ten (10)
Patient Security Straps	Three (3)	Three (3)	Three (3)	Three (3)	Three (3)
Replacement Parts	Wood Slats, Buckles	Wood Slats, Buckles	Wood Slats, Buckles, Transport Bags	Wood Slat, Buckles	Wood Slat, Buckles
					

* Other variations and colors available according to customer requests.

** Body cover constructed of 10 oz. vinyl.

SPECIALTY



Stadium Stretchair

RSS0059 (Orange)

The Reeves Stadium Stretchair is used to quickly transport victims from stadiums, sport facilities, arenas, theatres or anywhere multiple steps create problems when removing patients. It can carry in excess of 1,000 lbs (per independent laboratory testing), and is constructed of lightweight 18 oz. vinyl-coated polyester that is easily washed with soap and water, highly resistant to acids and alkali, and unable to be penetrated by liquids. Hardwood slats positioned between two (2) layers of fabric provide strength and rigidity. Four (4) ergonomically-placed handles constructed of polypropylene webbing with foam inserts are built for comfort. Two (2) two-inch adjustable polypropylene web straps with plastic buckles are placed in strategic locations to secure the patient for maximum safety.

Dimensions:

Open: 35.5"L x 15.5"W

Folded: 18"L x 8.5"W x 5"H

Weight: 4.7 Lbs.

Replacement Parts: Buckles



Reeves Spine Board

RDA30440 (Orange); RDA30445 (Black)

Designed for patients with spinal and neck injuries, the Reeves Spine Board minimizes patient movement during transport. It has a load capacity of 1,000 lbs and is constructed of FDA UL Quantum resin, which is hazmat impermeable and x-ray translucent. Its tapered design, sixteen (16) hand holds, and multiple child and adult strapping locations, with strap and buckle set, make the Reeves Spine Board easy to use in any situation.

Dimensions: 72"L x 16"W x 1.1"H

Weight: 13 lbs.

Accessories: Webbing Set (RDA30460); Buckle Set (RDA30465); Transport Case (RSSB0002)



Splint Kit Set

RSM00002 (Orange)

A splint kit for use in case of an arm or leg fracture. Velcro straps allow for fast and easy application. Hardwood slats provide control and stability for either an arm or a leg. The 18 oz. vinyl-coated fabric covers allow for quick, easy clean up. A carry case is also included.

Weight: 5 lbs.

PRODUCT SUPPORT

Whether you are a new or existing customer, DHS Systems offers a number of ways to get in touch with its many representatives. With support facilities located throughout the United States and in different corners of the globe, DHS Systems' professionals provide 24/7 customer service, technical support and product information via phone, email or on location.

All of DHS Systems' customer support, logistics and business development professionals are former technical or military personnel who understand and appreciate the needs and concerns of their fellow Soldier, Marine, or Airman out in the field. Many used DRASH equipment prior to separating from the service, so they know that a rapid response time is crucial to any military deployment or exercise.

Whatever your needs, DHS offers a wide range of services to meet your customer support needs.

Logistics Services

- 24-hours, 7-days a week customer hotline.
- Free new equipment training. Refresher training for troops rotating into new units also available.
- Warranty service and replacement parts as required.
- Periodic maintenance and service on all DRASH equipment, shelters, trailers, generator sets, heaters, power distribution units and environmental control units.
- Emergency maintenance and service on all DRASH equipment.
- Onsite field support during training exercises.
- Onsite field support for deployments to overseas locations.
- Global service contracts.
- Spare and replacement parts.

Worldwide Support

In order to better support our customers, DHS Technologies' representatives are available through our 24/7 customer hotline at 877-GO-DRASH or drash@drash.com. Representatives are also available at the following locations and their surrounding areas:

FT. Bragg, NC: (910) 425-9614

FT. Stewart, GA: (912) 877-3040

FT. Riley, KS: (785) 537-8900

FT. Bliss, TX: (915) 633-1156

FT. Hood, TX: (254) 680-3004

FT. Lewis, WA: (253) 964-8586

FT. Carson, CO: (719) 375-0783

Germany: +49 (172) 724 1710

Korea: +010 - 2962 - 8275

Non-U.S. Customers:

+44 (0) 1432 277 197

Individual representatives are also available across the country. To find a representative near you, visit www.drash.com/poc.





CONTRACTING



DHS Technologies strives to uphold the best possible relationships with our customers and partners. We have a strong reputation for providing unsurpassed quality and service that has become a cornerstone of our business and synonymous with the DRASH and Reeves names.

With over 25 years of experience working with multiple branches of the US Military, allied nations, homeland security, first-responders, and commercial industry, DHS Technologies has demonstrated it is ready and willing to work with organizations at all levels to meet their needs. The company is fully committed to providing outstanding service and competitive prices to all of our clients. We offer a variety of purchasing vehicles to make it easy and straightforward for our customers to work with us. Some of these purchasing vehicles include:



Ordering Through GSA

For questions or quotes please contact drash@drash.com or **877-GO-DRASH**. You may also order through gsaadvantage.gov.

DRASH shelters and support equipment have recently undergone a significant price reduction and can be found by typing in GSA Contract number: GS-07F-8645C.

DRASH DC2E products are also now available at a reduced price through GSA and can be searched on gsaadvantage.gov by typing in GS-03F-0181V.



Ordering Through DLA/DSCP

US government orders via DoD/ DLA/DSCP can also be placed through DSCP Point of Contact Robin Gonzales, Phone: (215)

737-0388, Email: robin.kirkland-gonzales@dla.mil. Interested parties may also visit www.dla.mil for additional information.

Ordering Through the Open Market

Open Market items are also known as:

- Incidental Items
- Non-Contract Items
- Non-Schedule Items
- Other Direct Costs (ODC's)

All DRASH products can be ordered through the Open Market. Contact us at drash@drash.com or at **877-GO-DRASH** for details.

Ordering Through MIPR

Products may be ordered through MIPR. Contact us at drash@drash.com or at **877-GO-DRASH** for details.

Federal Grants DUNS/Bradstreet

DUNS code: 131695629

Ordering Through Commercial Means

Products are available for Commercial Customers. Interested parties may contact us at drash@drash.com and place "Commercial Inquiry" in the subject line of the e-mail.

Orders may also be sent to:

DHS Systems LLC
33 Kings Highway
Orangeburg, N.Y. 10962-1802
Phone (877) GO-DRASH, Fax (845) 365-2114

Ordering Through SARSS

DRASH parts are available in SARSS (Standard Army Retail Supply System). Email us at drash@drash.com or call **877-GO-DRASH** for more information.

Business Codes and DATA

Cage Code: 0WFM3
Standard Industrial Classification (SIC) Code 2394
NAICS Codes 314912, 333415, 334310

ADDITIONAL SUPPORT

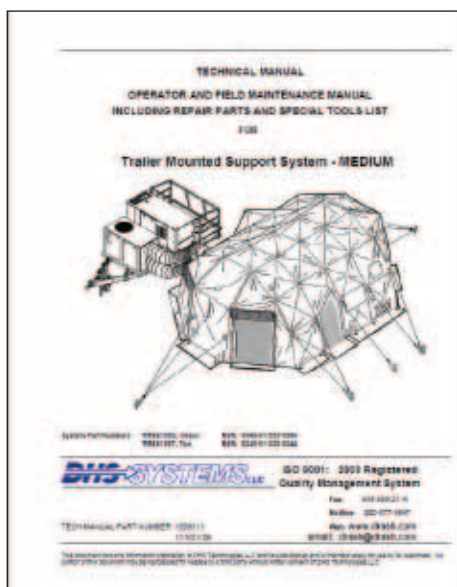

Support Manuals

DHS Systems offers a variety of user manuals for its shelters, trailers and support equipment. To request a manual, contact customer support at **877-GO-DRASH** or **drash@drash.com**. Make sure to indicate your shelter model or trailer vehicle identification number (VIN) or serial number.



Quarterly Newsletter

The *DHS Technologies Reporter* is a print and online quarterly newsletter for DRASH customers that includes product and company news, technical tips and tricks, and stories about DRASH deployed in the field.

To subscribe to the *Reporter*, visit **www.drash.com/newsletter** or contact the editor at **editor@drash.com**.



Online Videos

DHS Systems offers a series of informational videos on shelter and trailer deployment, strut replacement, connecting and moving shelters, securing doors and windlines, removing stakes, folding floors and ground tarps and cinching shelters.

To access these videos, visit **www.drash.com/videos**.



Virtual Tactical Applications Program (VTAP 2.0)

Whether you need to set up a TOC, build a medical complex or organize a life support area, DHS Systems makes it easy to build your own DRASH shelter system. The online DRASH Virtual Tactical Applications Program, or VTAP 2.0, allows the user to easily organize footprint ideas for shelters and related components on a virtual screen before sending it to a DRASH representative for further review. The program, which was recently upgraded in 2010, helps personnel visualize a complete footprint before deploying to the field or placing an order.

To access VTAP 2.0, visit **www.drash.com/vtap**.



Quality and ISO Compliance

DHS is Registered With ISO-9001:2008

The Quality Management System at DHS Systems LLC is registered to ISO-9001:2008 and has been registered with QMI since 1999.



Many of the company's products are also available to customers outside of the United States through DHS Systems International.

In 2004, DHS Technologies LLC established DHS Systems International Ltd (then known as MilSys (UK) Ltd) as its international subsidiary. Responsible for sales outside of the United States, the company sells numerous DRASH products while also offering its own unique product line.

Products unique to DHS Systems International range from CELOX™, a haemostatic agent that controls even the most severe bleeding, to CBRN containment gear for medical facilities, sanitation units, to power, environmental control and lighting equipment built to European Union (EU) requirements.

DHS Systems International is headquartered in Hereford, United Kingdom and provides training as well as sales, technical and maintenance support through a network of business development representatives and logisticians located around the world.

Many of the company's products have also been deployed by the armed forces of Austria, Brazil, Japan, Poland, Romania, Spain, Turkey and the United Kingdom.

Our products have also been used by numerous civilian response and disaster management teams including those in the countries of Chile, Italy, the Republic of Indonesia Ministry of Health, the Japanese Red Cross Society, and Bombeiros (firefighters) in the Brazilian State of Rio De Janeiro.

International attends numerous exhibitions each year and potential customers are encouraged to visit the company's headquarters to view ongoing operations.





AIR CONDITIONING



Movement of each unit can be achieved using a forklift or crane; the smaller CTZ6H55 and CTZ10H55 can also be manoeuvred manually with wheels and foldable handles.

Technology You Can Trust

Growing in use among European Forces, this air conditioning technology is based on over 50 years of experience in cold logistics and air conditioning in extreme conditions. Its current capability to provide cooling capacities ranging from 6 to 23kW was developed in collaboration with French Forces.

Features:

- Provide cooling and heating to any working or living environment.
- Robust design allows each unit to withstand frequent movement within the field.
- Connect to a facility via two (2) insulated ducts.
- Designed to operate in temperatures of up to +55°C.
- Cooling capacities from 6 to 23 kW.
- Easy to manoeuvre.
- Suitable for use in extreme conditions.
- Easy to maintain and service.

Air Conditioning Units provide cooling and heating to DRASH shelters or any other facility where temporary air conditioning is needed.

Operational Design

Able to provide cooling capacities ranging from 6 to 23kW, each air conditioner unit can be rapidly deployed to the field and connected to the outside of a DRASH shelter by two insulated ducts. The air conditioners have also been built to withstand extreme climatic conditions and physical constraints - remaining operable in temperatures of up to +55°C.

	CTZ6H55	CTZ10H55*	CTZ16H55*	CTZ23H55*
Ducts (supply/return)	2	2	2	2
Cooling Capacity (kW)	5.6	10.2	16.1	22.5
Heating Capacity** (kW)	3	6	9	12
Length (m)	1.3	1.3	1.6	1.6
Width (m)	0.7	0.7	0.9	0.9
Height (m)	1.0	1.0	1.1	1.1
Weight (kg)	145	175	400	450

*Also available as a "2T" version featuring four ducts for use with two shelters.

**Optional electrical heating is available for all models.

LIGHTING



Lighting provides a non-glare bright light that is suitable for both indoor and outdoor use. Available in two configurations - UPS and Dimmable - the lights are normally sold as 230 V, but other voltages are available upon request.

	UPS (230 V)	DIMMABLE (230 V)
Light source TCL/840	2 x 36 W	2 x 55 W/e
Ballast	low-loss	electronic
Luminous Flux/ Lm (approx)	5800	9600
Capacity (approx)	110 W	125 W
Equivalent bulb of	500 W	750 W
Burning Time	8,000 hrs	10,000 hrs
Dimensions in mm (approx)	485 x 145 x 190	610 x 145 x 190
Voltage	230 V/ 50 Hz	230 V/ 50 Hz
Protection Class	IP54	IP54
Protection Zone	I	I
Heat Radiation	F luminaire	F luminaire
Dist. to radiated services	0.3 m	0.3 m
Permissible ambient temp.	-25° to +55°C	-25° to +55°C
Weight (approx)	3.6 kg	3.2 kg



INTERNAL POWER MANAGEMENT SYSTEMS



Each DRASH Internal Power Management System includes:

- Power distribution block with 5 x 230V RCBO-protected 16A Sockets.
- 230V RCBO-protected 16A Schuko socket with a 5m cable and a 3-Phase 32A 230V male plug.
- 5m cable with 16A male and female ends.
- 1.5m cable with 16A male and female ends, 1m cable with a male end and a 3 trailing socket.

DRASH Internal Power Management Systems allow for electrical cabling inside any DRASH shelter.

Each system includes a power distribution box (PDB) that can be configured for either 32 amp single-phase or three-phase power. Each unit also comes complete with Residual Circuit Device (RCD) protection, and each individual circuit is protected by its own 30mA RCBO. Additionally, each system's outlets can be custom-made to accommodate a shelter's size and unique power requirements, or to match outlets not designed to EU standards.

Though each unit's PDB does not come standard with a power in cable, customers can purchase these as needed. Various-sized extensions cables are also available.

All included and optional components meet current UK safety electrical equipment standards.

DRASH External Power Management System
DHS Systems International also offers a DRASH External Power Management System that allows for electrical cabling outside any DRASH shelter to provide power to air conditioners, heaters and other similar support equipment. The system includes a generator interface unit (GIU) and all necessary cables.



IPMS Scaling						
	Bag	25A PDB	5m Lead	1.5m Lead	1m Lead	3 Way Splitter
DRASH 1XB / 1S	1	1	1	2	3	0
DRASH 2XB / 2S	1	1	1	2	3	0
DRASH 3XB / 3S	2	2	2	3	5	0
DRASH 4XB / 4S	2	2	4	4	5	0
DRASH 5XB / 5S	2	2	4	4	5	0
DRASH 6XB / 6S	2	2	6	6	6	0
DRASH M, MX & MX5	2	2	6	6	6	0
DRASH J	2	2	15	10	10	0

D-1000B(E) HEATER



- Watertight control panel.
- Runs over 13 hours continuously without refueling fuel tank.
- High temperature sensor in heat exchanger – safety shut off.
- Accurate solid-state remote thermostat control.
- Electronically controlled fuel injection.
- Remote CO (Carbon Monoxide) detector.
- 0.3 m x 4.6 m flexible duct sections (supply and return).
- Visual fuel gauge.
- Fabric duct end covers.

The D-1000B(E) Heater is rugged, lightweight, rust resistant, shock proof and easy to operate and maintain, providing nearly 100,000 BTU/h of dry, clean heat at a rate of 1,150 CFM. The heater includes an electronic control system that monitors for high heat conditions and flameout, as well as a pre-heated fuel filter that allows the heater to continue to operate in even extreme low temperatures. It can also continuously run for more than 13 hours without the need to refuel, ensuring personnel will have a steady, reliable heat source while working in the field.

Features:

- Indirect fuel fired air heater – “Heater Air” is separated from exhaust air passage.
- Pre-heated fuel filter allows heater to work continuously in extreme low temperatures.
- Adjustable fresh air make-up inlet window.
- Safety production:
 - Safety shut off switch if flame is not detected – flame detector.
 - High temperature limit switch shuts down heater if ducts become blocked (exceeding 121°C).
 - Safety shut off switch upon detecting 100ppm of CO content.
- High efficiency heating output of 100,000 BTU/h.
- Stainless steel combustion chamber.
- Two piece moulded polyethylene skid and cover.

Specifications:

- Combustion: Indirect heat exchanger.
- Heat Input Capacity: 110,000 BTU/h.
- Air Flow: 1,150 cfm.
- Fuel Consumption: 0.72 UK gal/ h / 3.25 l/h.
- Nozzle: 0,55-80°W.
- Pump Pressure: 13.5 bar.
- Fuel Tank Capacity: 9 UK gal / 45 l.
- Power Supply: Variable Voltage; 110/240V, 1 ~ 50Hz.
- Power Consumption: 370 W.
- Fuse: 10A.
- Flue Diameter: 15 cm.
- Noise Level at 1m: 74 dBA.

Weight:

Total dry weight without accessories: 75 kg.
Ducts: 12.5 kg each.

Dimensions:

Unit: 1.4 m L x 0.6 m W x 0.8 m H.
Ducts: 0.3 m D x 0.4 m L.



CELOX™ is a haemostatic agent that controls even the most severe bleeding, fast.

CELOX™ combines with red blood cells and platelets to form a gel-like clot that can be used to treat patients suffering from clotting disorders or those with mild to severe injuries.

Already in use across the globe, including with the British Armed Forces, CELOX™ is suitable for use by a wide range of customers, including armed forces, first responders and hospitals. It can also be used to support industrial first aid, emergency services, wilderness medicine, adventure pursuits, professional and amateur sports and, of course, as a must-have for your home or car first aid kit.

Features:

- Does not generate heat.
- Works independently of normal blood clotting factors.
- Simple and safe to use.
- Not exothermic; will not burn the victim or caregiver.
- Works in hypothermic conditions and clots Heparinized blood.
- Safe for use on the entire body, including on head, neck and chest wounds.

Able to treat a wide range of injuries, CELOX™ is available in a various forms:

CELOX™ Granules

Trusted around the world, CELOX™ Granules are safe, effective and easy to use - just pour the contents into the wound, pack and apply pressure. CELOX™ Granules, which have been tested to class 3 CE Mark standards, are available in 35g and 15g packs.

CELOX™ Applicator

CELOX™ Applicator, or CELOX-A™ is a unique applicator delivery system designed to give you an easy and effective way to stop life-threatening bleeding from difficult-to-treat, penetrating trauma. The instinctive applicator allows you to get CELOX™ Granules through a small entry wound and directly to the bleeding site in just a few seconds.

It is suitable for a wide range of injuries, including small entry wounds, penetrating wounds, knife and shrapnel wounds and bullet entry wounds.

CELOX™ Gauze

CELOX™ Gauze is an instinctive way to control severe and catastrophic bleeding. Users simply have to pack the wound and apply pressure.

CELOX™ Gauze consists of highly effective CELOX™ Granules bonded to the surface of a stable gauze, which does not compact under pressure. This gives first responders the ideal tool to deal with life-threatening bleeds.

CELOX™ Z-Fold

CELOX™ Z-Fold is the latest development of the trusted Celox product range.

The new compact design for Celox Z-Fold (14mm thick, 34g weight) allows multiple packs to be carried, makes for easier handling and reduces application time.

Celox Gauze Z-Fold comes in 5ft lengths, and is as effective as other 10ft and 12ft length products in filling a bleeding space.

ASSET MANAGEMENT & MAINTENANCE



DHS Systems International's comprehensive asset management programme allows customers to focus on their core operations while DHS works to ensure their equipment remains at the optimum level of serviceability and readiness to deploy. As part of the programme, the company will not only store a customer's equipment according to their specific requirements, but maintain the equipment before and after deployments as well.



Services:

- Continual cleaning, maintenance & checking of equipment.
- Pre-deployment checks.
- Secure storage.
- Insurance - new for old.
- Assets held according to customer's requirements.
- 24-hour access to assets.
- Short notice deployment of equipment.
- Field support.

Field Maintenance at a Moment's Notice

In support of all of its products, DHS Systems International's highly-skilled maintenance team offers its services to customers across the globe. From minor to major repairs, DHS Systems International can complete maintenance work at its headquarters in Hereford, England, or at a customer's premises or current location in the field. Maintenance can often be scheduled at very short notice and even larger quantities of equipment can be taken in at any one time.

DHS Systems International also sells an extensive range of spare parts to those customers who wish to carry out their own maintenance, particularly for repairs in the field.

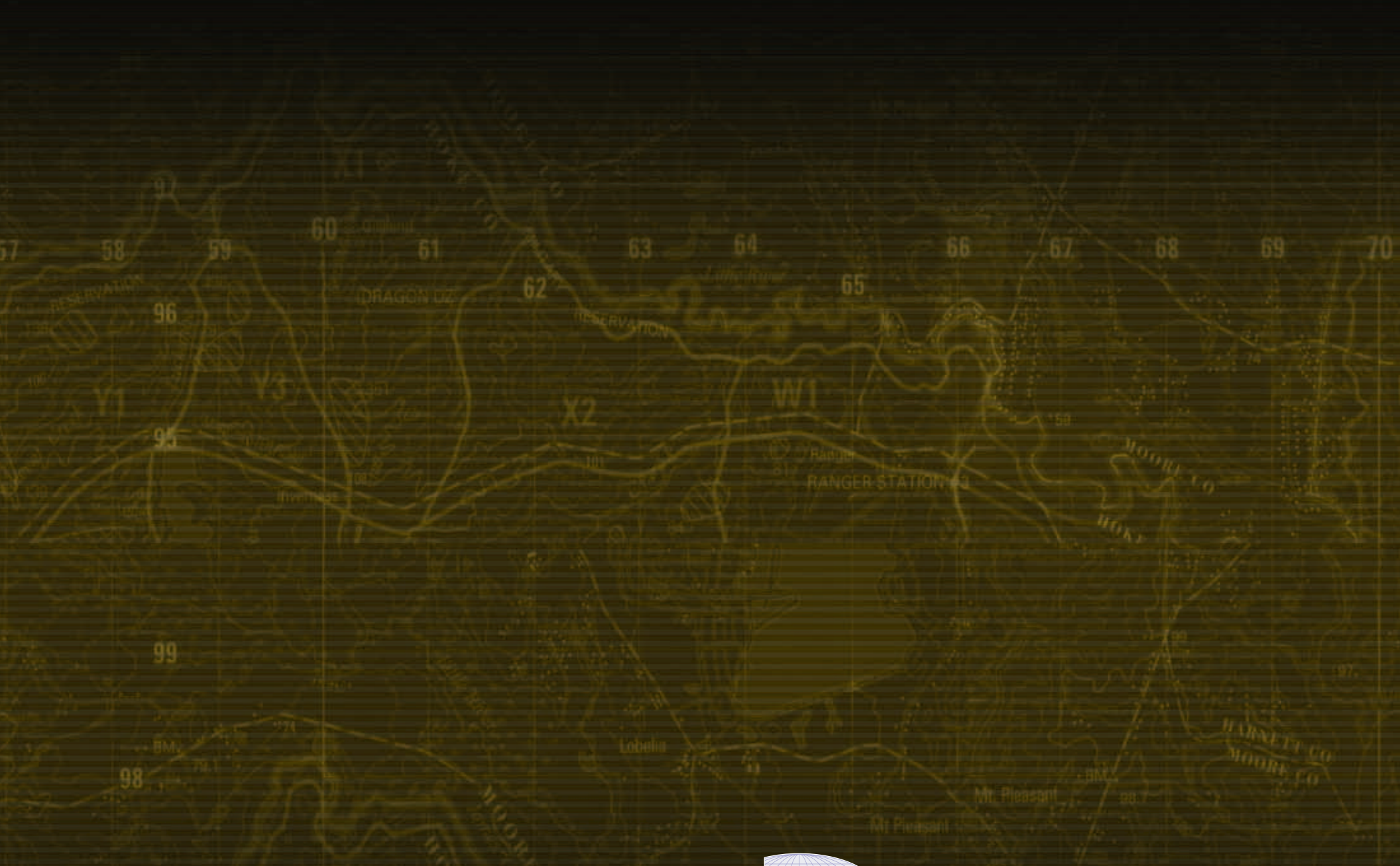

DHS SYSTEMS LLC



DHS TECHNOLOGIES COMPANIES

1-877-GO-DRASH

drash@drash.com

www.drash.com