



## PANDA AGT 4000/24V PVMV-N



Generator	Panda AGT 4000/24V PVMV-N Water-cooled DC Generator
Constant Output	3,8 kW at sea level / +50°C
Output Voltage	24(28)V DC
Output Current	135A
Start System	24V Electrical
Engine Manufacturer	Kubota
Engine Type	EA 300
Engine Cylinders	1
Engine Operating Temp. Range	-20°C up to +50°C (other temperature ranges on request)
Fuel Types	F 34, F 54 ,Standard automotive diesel fuel, kerosene, JP 8, JP 5, JET A
Approx. Fuel Consumption <sup>1)</sup>	0.4 - 1.5 l/h
Fuel Supply	Connections for external or vehicle fuel tank
Frame / Mounting	Generator mounted inside sound insulated capsule
Cooling System	Uses external radiator for cooling.
Instrumentation & Electrical	Externally Mounted Panel
Approx APU weight*	142 kg without radiator (dry)

\*Note the wet weight for APUs with integrated fuel tanks is excluding fuel unless stated.



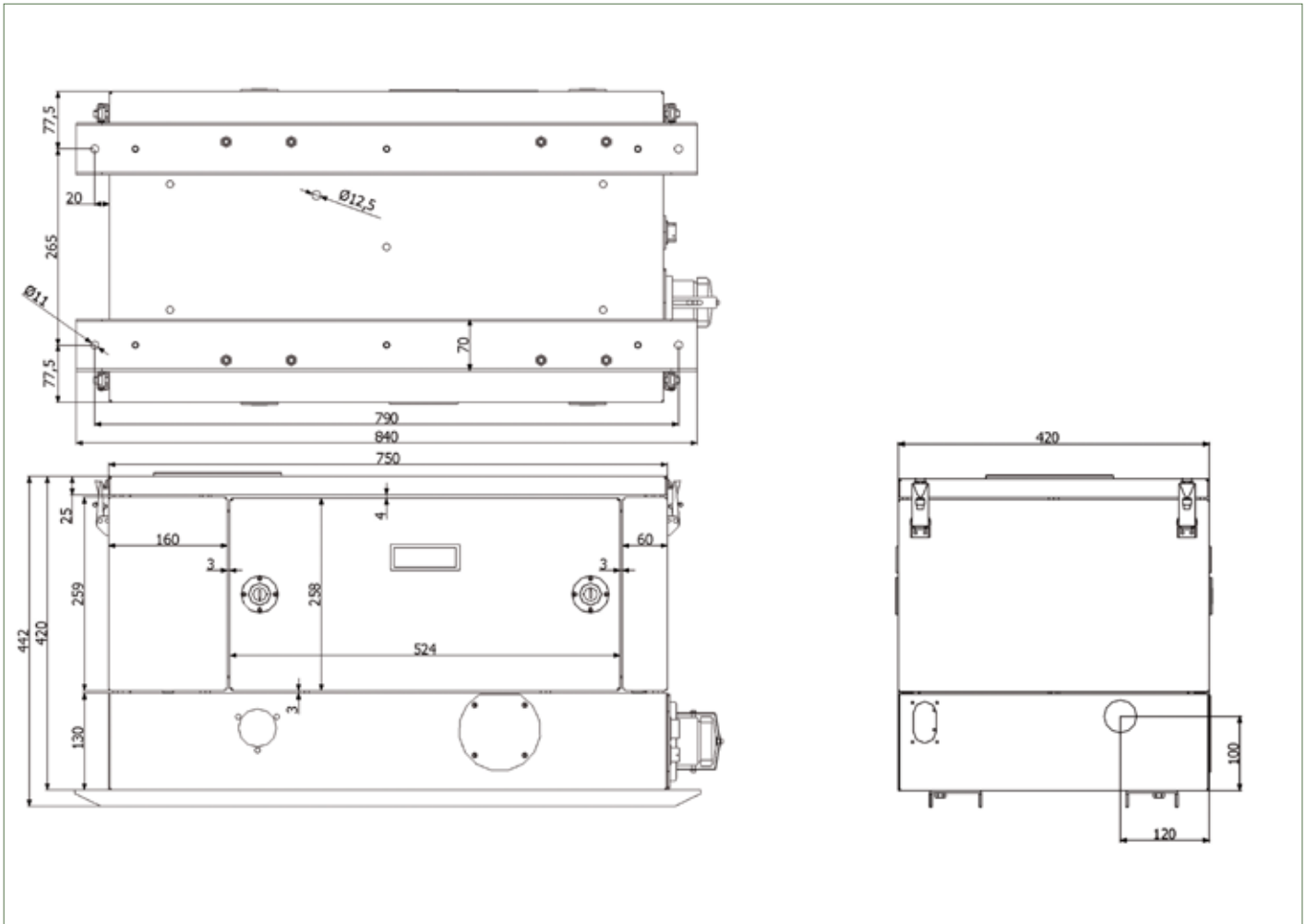

### Fischer Panda Generators and APUs for Military Applications

Fischer Panda has a full military specification for its generators, meeting a wide range of **MIL-STD** requirements especially concerning EMI levels and IR signatures, exhaust emissions and operating sound levels. They are designed with fast and easy maintenance in mind, whatever the conditions or circumstances, which is essential for the military operator. Custom-built generators can be constructed as practically all the main components are manufactured by Fischer Panda. Effective use of water-cooling and installed within a sound-insulated housing, they operate quietly, are practically vibration-free with a minimal thermal signature.

**Fischer Panda DC generators** enhance lighter vehicle systems with powerful charging capabilities and enabling silent running. The DC PE150 Series, for example, is perfect for automatically maintaining battery systems onboard M113 tracked vehicles.

**The Fischer Panda AC generators** supply electricity with a very clean sine wave suitable for sensitive elec-

trical equipment. They are also capable of providing sufficient power for starting heavier equipment such as environmental control units (ECUs). With parallel load switching and parallel load sharing options available, the generators can function as decentralised power assets to manage peak demands for power during operations. They can then combine power output or swapping the load to sustain a supply. The latest range of SST Generators feature engines capable of running at variable speed while maintaining a constant frequency. They can adjust the speed to match the load with significant fuel savings, reduced wear and lower exhaust emissions. These generators can also offer full load sharing capabilities.

Fischer Panda builds specifically for vehicles with dedicated generator tunnels. These have been enhanced to form a **Combo Generator**, featuring an AC generator and high efficiency ECU in a single unit.

### Combined Air-conditioner and Power System (CAPS) for container-based applications

This is a highly sophisticated system for container-

based applications requiring electrical power, advanced ECU heating and air-conditioning. By fully utilising performance, management and self-testing features, the CAPS can maintain an optimal environment for sensitive electronic equipment and personnel to operate. This system offers thermo-management capabilities so heat can be supplied from three different sources: heat as "by product" from the generator, integrated diesel heating and heat produced electrically. With air-conditioner output depending on the altitude using Active Performance Management ensuring full electrical supply of the shelter. The CAPS system is designed for command units maintaining a heightened "battle readiness" and who are expecting disruption or total loss of the mains power grid. Upon loss grid power, the generator is automatically started and the supply switched over. This can also be done manually. Electrical systems are supplied via multiple electrical outlets with isolation transformer protection. During periods of inactivity, advanced "Built-In Test Equipment" allows the CAPS System to start and automatically accomplish system tests to ensure it is functioning correctly.

**Disclaimer:** The information contained here is to the best of our knowledge accurate at the date of publication. Please note that the data in this publication reflects the technical state at time of print. Due to our policy of continual product development, we reserve the right to alter technical specifications without notice.

Stand: 05.2016 Ref: Panda\_AGT\_4000-24V\_PVMV-N\_REF\_002\_003\_ID\_5



Fischer Panda UK Ltd.  
17 Blackmoor Road,  
Ebble Estate, Verwood  
Dorset. BH31 6AX

Tel. : 01202 820 840  
Fax : 01202 810 082  
Email : [info@fischerpanda.co.uk](mailto:info@fischerpanda.co.uk)  
Web : [www.fischerpanda.co.uk](http://www.fischerpanda.co.uk)

